

CM Series

CLOSED COUPLED CENTRIFUGAL PUMP

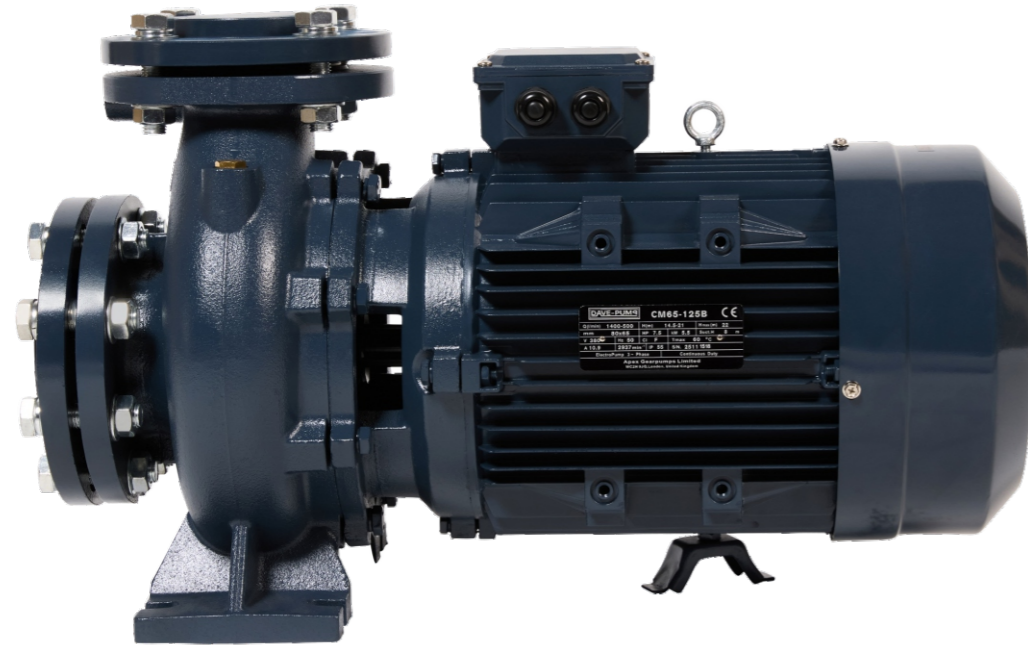

DESCRIPTION & FEATURES

CM series standard centrifugal pumps is our new development products, it is a single stage high efficiency electric pumps, mounting with the steady motor, with small consumption. It can reach a good performance in big capacity and high pressure head.

It is with the single closed construction, easy for maintaining, testing and replacing the easy damage part, and it's easy to operate during the reliability using.

They are widely used in well-pumping, water supplying, electric power, mine, mixing and irrigating for civil, industry and agriculture, etc.

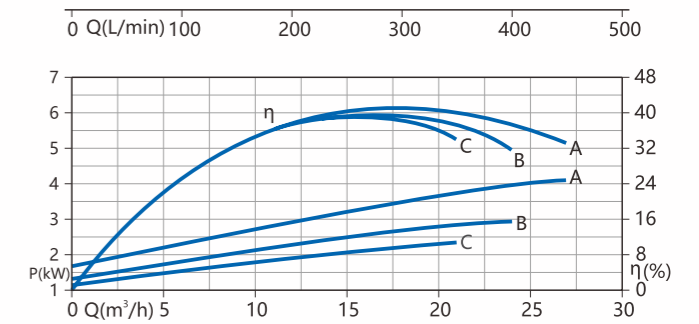
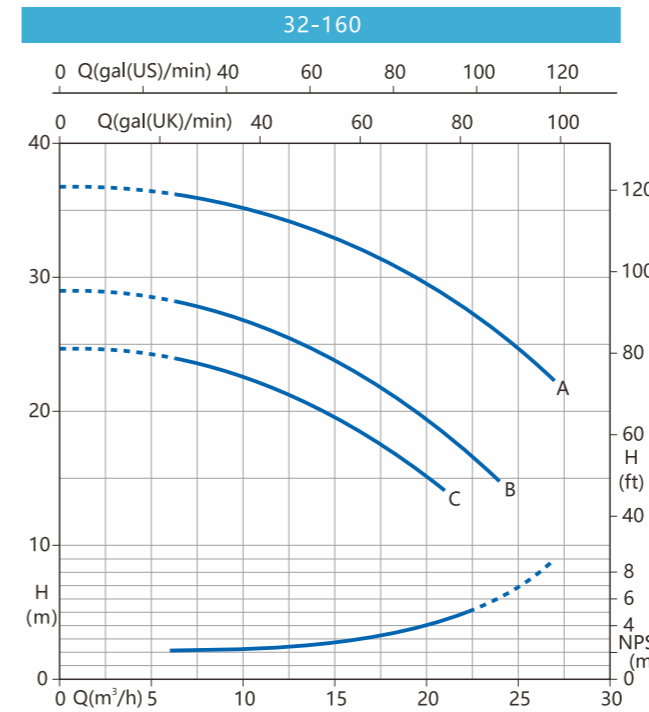

TYPE	P2		P1 (kW)	Q(m³/h-L/min)										
				H(m)										
	(HP)	(kW)	3~	0	4.5	6	7.5	9	12	15	18	21	24	27
32-160 C (*)	2	1.5	2.3	24.7	24.4	24.1	23.6	23	21.5	19.6	17.2	14.1	--	--
32-160 B (*)	3	2.2	2.9	29	--	28.5	28	27.3	25.7	23.8	21.4	18.5	14.8	--
32-160 A	4	3	4.1	36.8	--	36.4	36	35.4	34.2	32.8	31.1	28.8	26	22.3

Other voltages and frequencies available on request.

(*) Single phase available.

MATERIALS TABLE

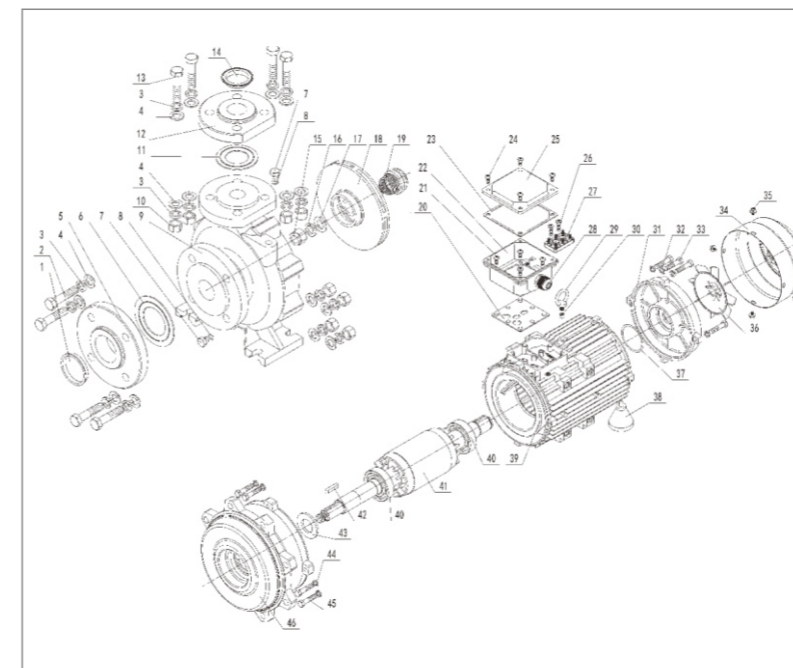

NO.	DESCRIPTION	NO.	DESCRIPTION
1	Seal	24	Screws
2	Hexagon bolts	25	Terminal Box Cover
3	Spring washers	26	Screw
4	Plain Washers	27	Terminal Blocks
5	Flange	28	Wire Sleeve
6	Joint Gasket	29	Ring Screws
7	Vapor Nail	30	Tightening Screws
8	'O' ring	31	Rear cover
9	Pump Body	32	Spring washers
10	Hexagon nuts	33	Hexagon bolts
11	Flange Gasket	34	Fan cover
12	Flange	35	Screws
13	Hexagon bolts	36	FAN
14	Seal	37	Adjusting ring
15	Anti-slip nuts	38	Foot
16	Spring washers	39	stator
17	Plain Washers	40	Deep groove ball bearings
18	Impeller	41	Rotor
19	Mechanical Seals	42	Key
20	Terminal Box Seat Gasket	43	Splash Guard
21	Screws	44	Spring washers
22	Terminal Box Seat	45	Hexagon bolts
23	Terminal Box Cover Gasket	46	Front cover



32-200

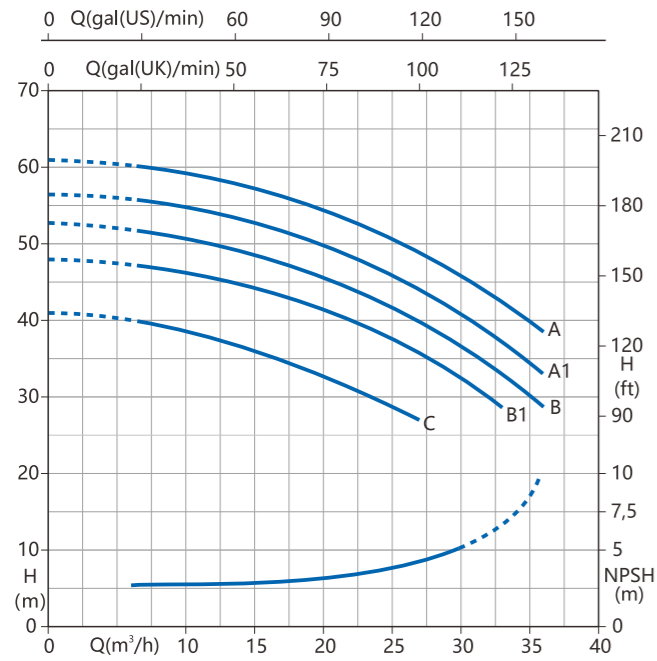

32-250

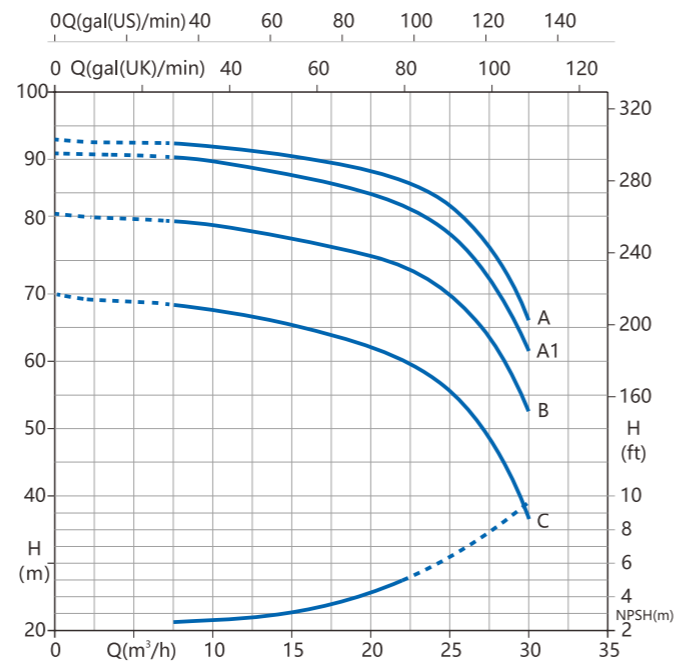

40-125

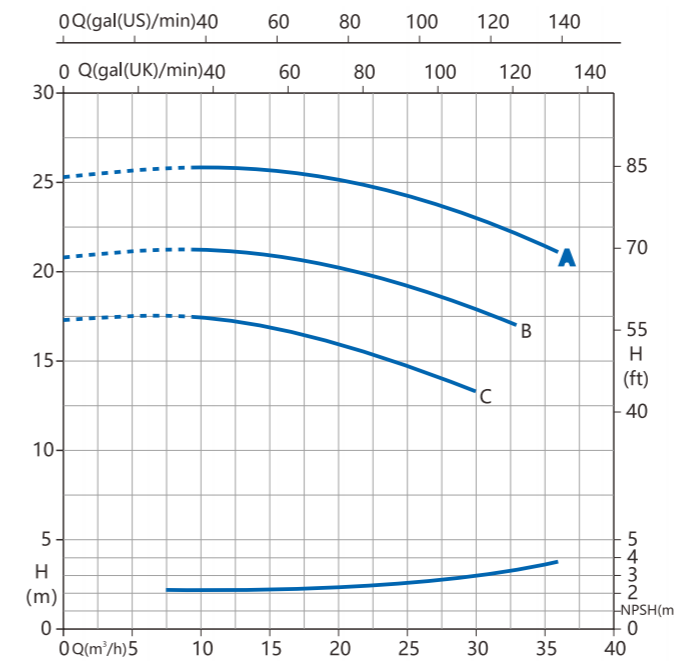

40-160

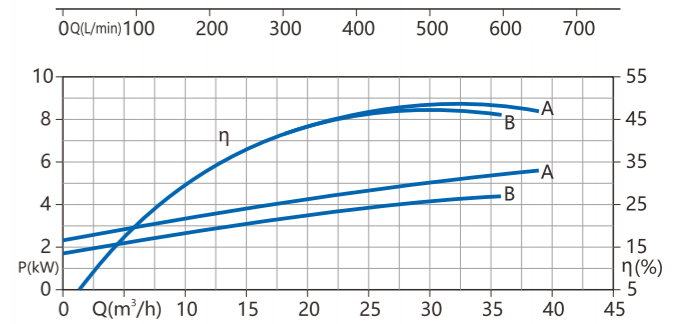
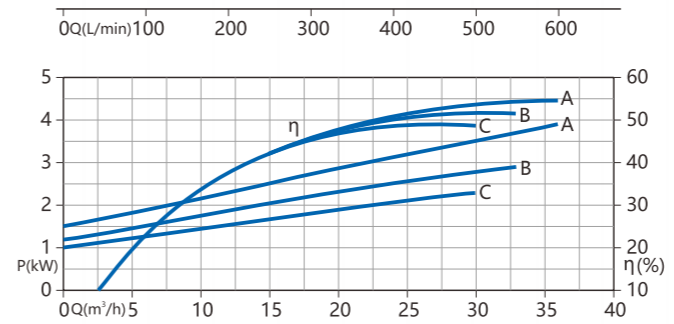
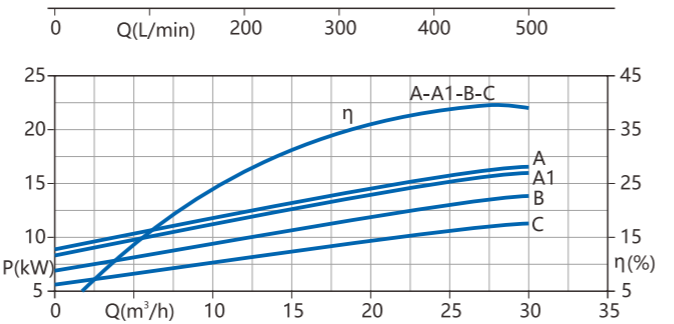
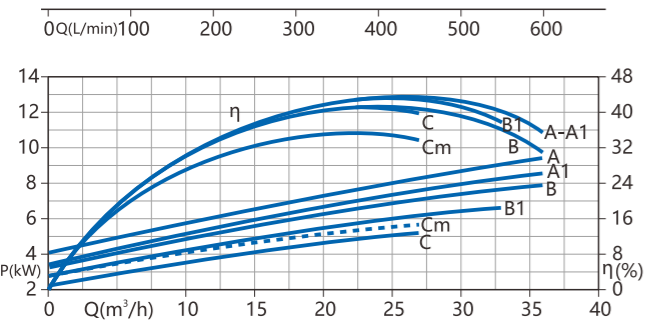
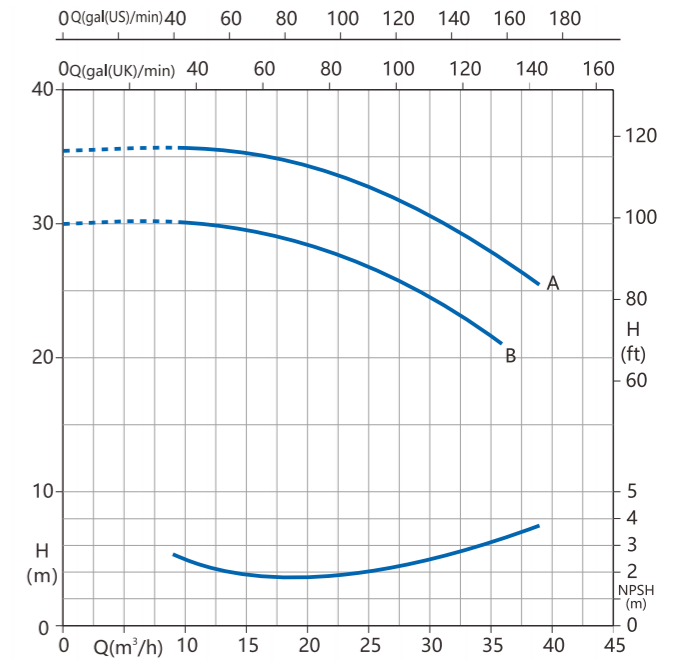

TYPE	P2		P1 (kW)	Q(m³/h-L/min)												
				H(m)												
				0	6	7.5	9	12	15	18	21	24	27	30	33	36
3~	(HP)	(kW)	3~	0	100	125	150	200	250	300	350	400	450	500	550	600
32-200 C (*)	5.5	4	5.2	41	40	39.5	38.9	37.5	36	34.2	32.2	30	27	--	--	--
32-200 B1	7.5	5.5	6.6	48	47.5	47.1	46.6	45.5	44.3	42.5	40.7	38.5	35.7	32.5	28.6	--
32-200 B	7.5	5.5	8.2	52.8	52	51.5	51	50	48.5	46.8	45	42.7	40.1	37	33.3	28.7
32-200 A1	10	7.5	8.5	56.5	56	55.6	55.2	54	52.8	51	49.2	47	44.2	41	37.1	33
32-200 A	10	7.5	9.9	61	60.5	60.1	59.6	58.5	57.2	55.5	53.7	51.5	49	46.2	42.7	38.5

Other voltages and frequencies available on request.

(*) Single phase available.

TYPE	P2		P1 (kW)	Q(m³/h-L/min)									
				H(m)									
				0	7.5	9	12	15	18	21	24	27	30
3~	(HP)	(kW)	3~	0	125	150	200	250	300	350	400	450	500
32-250 C	12.5	9.2	11.9	70	68.5	68	67	65.5	63.5	61	58	50	36.5
32-250 B	15	11	14.4	82	81	80.5	79.5	78.5	77	74.5	71.9	65	52.5
32-250 A1	20	15	16	91	90	89.9	89	88	86	83.5	80.8	74	61.5
32-250 A	20	15	18.1	93	92.5	92	91.5	90.5	89.5	87.5	85	78.5	66

Other voltages and frequencies available on request.

TYPE	P2		P1 (kW)	Q(m³/h-L/min)												
				H(m)												
				0	7.5	9	12	15	18	21	24	27	30	33	36	
3~	(HP)	(kW)	3~	0	125	150	200	250	300	350	400	450	500	550	600	
40-125 C (*)	2	1.5	2.3	17.4	17.6	17.5	17.3	16.9	16.4	15.8	15.1	14.2	13.3	--	--	
40-125 B (*)	3	2.2	2.9	20.7	--	21.3	21.2	21	20.6	20.1	19.4	18.7	17.9	17	--	
40-125 A	4	3	4.1	25.2	--	25.8	25.8	25.6	25.4	24.9	24.4	23.7	22	22	21.1	

Other voltages and frequencies available on request.

(*) Single phase available.

TYPE	P2		P1 (kW)	Q(m³/h-L/min)													
				H(m)													
				0	9	12	15	18	21	24	27	30	33	36	39		
3~	(HP)	(kW)	3~	0	150	200	250	300	350	400	450	500	550	600	650		
40-160 B (*)	4	3	4.4	30	30.1	30	29.6	29	28.2	27.1	25.9	24.4	22.8	21	--		
40-160 A (*)	5.5	4	5.7	35.4	35.6	35.5	35.3	35	34.2	33.2	32	30.6	29	27.3	25.4		

Other voltages and frequencies available on request.

(*) Single phase available.

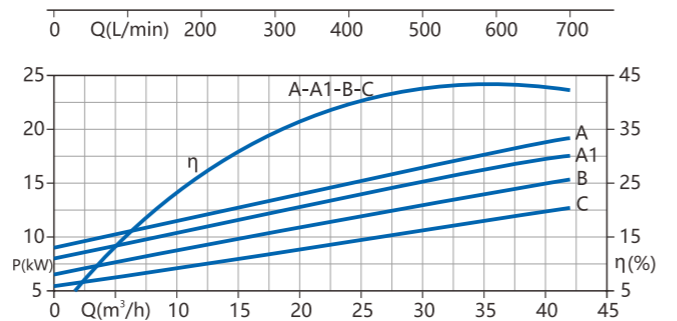
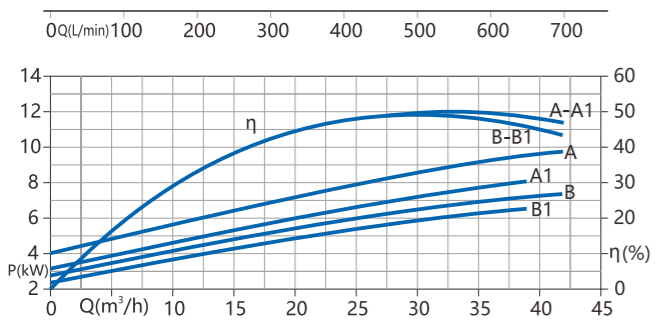
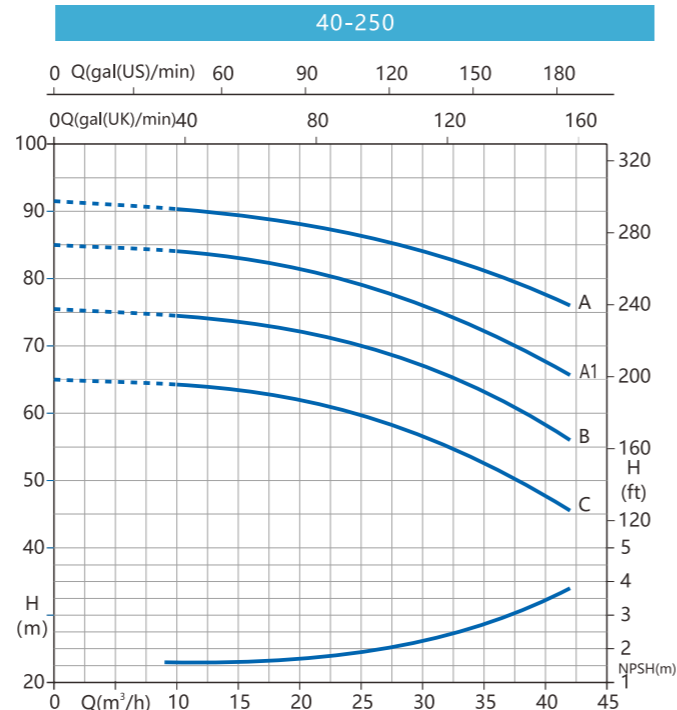
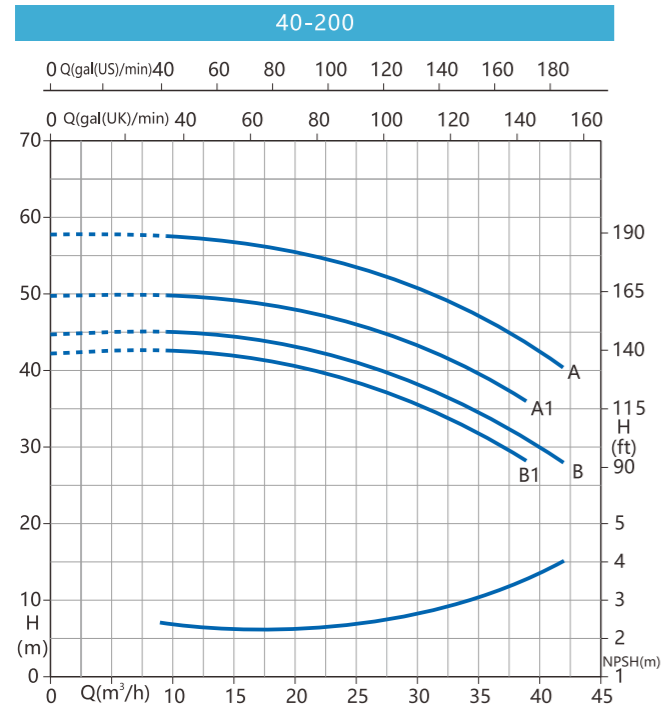

TYPE	P2		P1 (kW)	Q(m³/h-L/min)												
	(HP)	(kW)		3~	0	9	12	15	18	21	24	27	30	33	36	39
40-200 B1	7.5	5.5	6.5	42.2	42.4	42.3	42.1	41.3	40.3	39.1	37.5	35.5	33.3	30.7	28	--
40-200 B	7.5	5.5	7.4	44.7	44.9	44.8	44.6	44	42.9	41.6	40	38.1	36.1	33.6	30.8	27.9
40-200 A1	10	7.5	8.1	49.7	49.7	49.7	49.4	48.7	47.9	46.6	45	43.2	41.1	38.6	35.9	--
40-200 A	10	7.5	9.8	57.7	57.7	57.5	57.1	56.3	55.4	54.1	52.5	50.5	48.5	45.9	43.3	40.3

Other voltages and frequencies available on request.

TYPE	P2		P1 (kW)	Q(m³/h-L/min)												
	(HP)	(kW)		3~	0	9	12	15	18	21	24	27	30	33	36	39
40-250 C	12.5	9.2	12.6	65	64.3	63.9	63.3	62.6	61.5	60.2	58.8	56.9	54.5	51.6	48.5	45.5
40-250 B	15	11	14.4	75.5	74.6	74.2	73.5	72.7	71.7	70.4	69	67.2	65	62.5	59.5	56
40-250 A1	20	15	17.5	85	84	83.7	82.9	82.1	80.8	79.5	77.8	75.9	73.8	71.3	68.4	65.8
40-250 A	20	15	19	91.5	90.4	89.9	89.3	88.5	87.5	86.6	85.5	84	82.5	80.5	78.5	76

Other voltages and frequencies available on request.

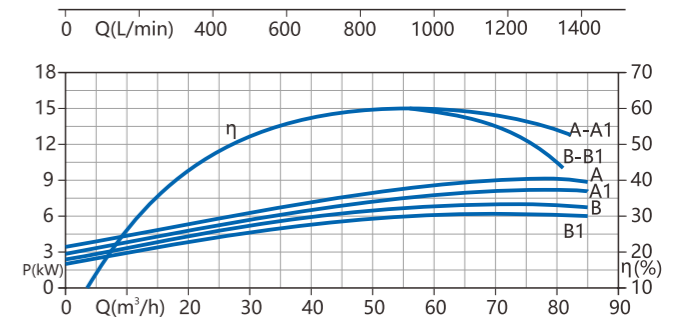
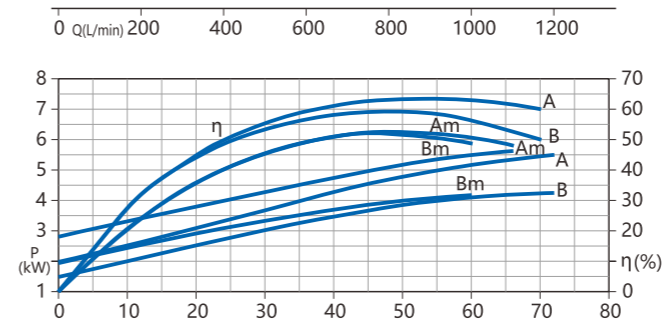
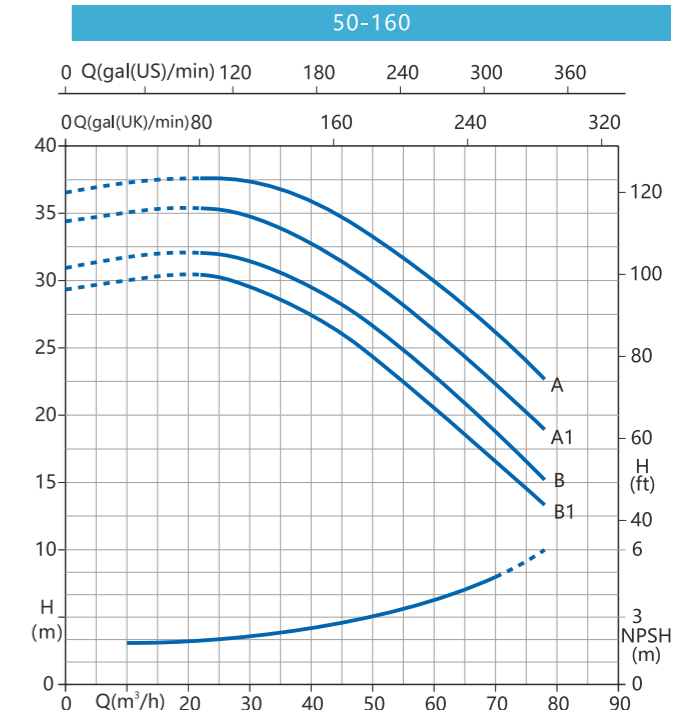
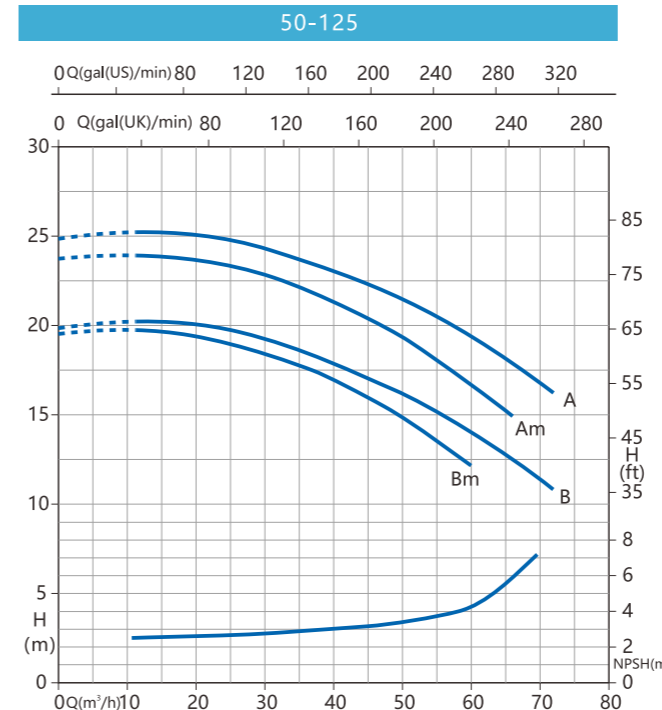

TYPE	P2		P1 (kW)	Q(m³/h-L/min)																		
	(HP)	(kW)		1~	3~	0	12	15	18	21	24	27	30	33	36	39	42	48	54	60	66	72
50-125 B	4	3	4.25	--	19.8	20.2	20.2	20.1	20	19.8	19.5	19.3	18.8	18.5	18	17.6	16.5	15.3	14	12.5	10.8	
50-125 Bm	-	4	3	4.2	--	19.5	19.7	19.6	19.5	19.3	19	18.7	18.4	18	17.6	17.1	16.6	15.3	13.8	12.1	--	--
50-125 A	5.5	4	5.5	--	24.8	25.2	25.2	25.1	25	24.8	24.6	24.3	23.9	23.5	23.2	22.7	21.8	20.7	19.4	17.9	16.2	
50-125 Am	-	5.5	4	5.6	--	23.7	23.9	23.8	23.7	23.6	23.4	23.1	22.8	22.4	22	21.5	20.9	19.7	18.3	16.7	14.9	--

Other voltages and frequencies available on request.

TYPE	P2		P1 (kW)	Q(m³/h-L/min)														
	(HP)	(kW)		3~	0	21	24	27	30	33	36	39	42	48	54	60	66	72
50-160 B1	7.5	5.5	6.2	29.3	30.3	30.2	30	29.6	29	28.4	27.7	26.9	25.2	23.2	21	18.7	16.1	13.2
50-160 B	7.5	5.5	6.7	31.1	32.1	32	31.7	31.4	31	30.4	29.7	28.9	27.3	25.3	23.1	20.7	18	15.2
50-160 A1	10	7.5	8.3	34.3	35.4	35.3	35	34.7	34.3	33.8	33.2	32.4	30.7	28.7	26.5	24.3	21.8	19
50-160 A	10	7.5	9.4	36.7	37.9	37.8	37.7	37.4	37.1	36.6	36.1	35.4	33.9	32.1	30	27.8	25.3	22.6

Other voltages and frequencies available on request.



50-200

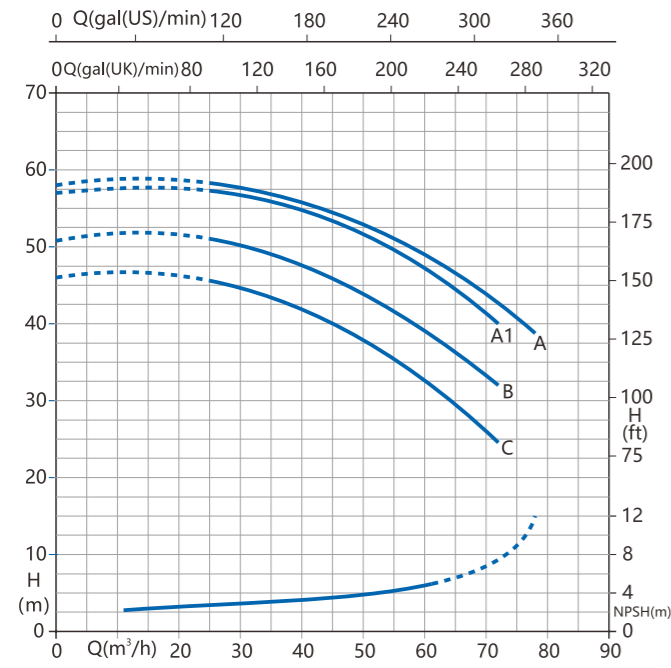

50-250

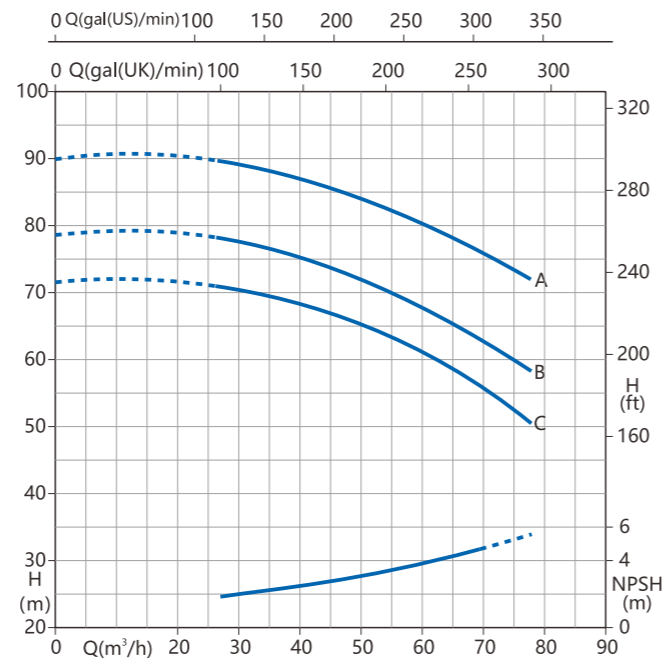

65-125

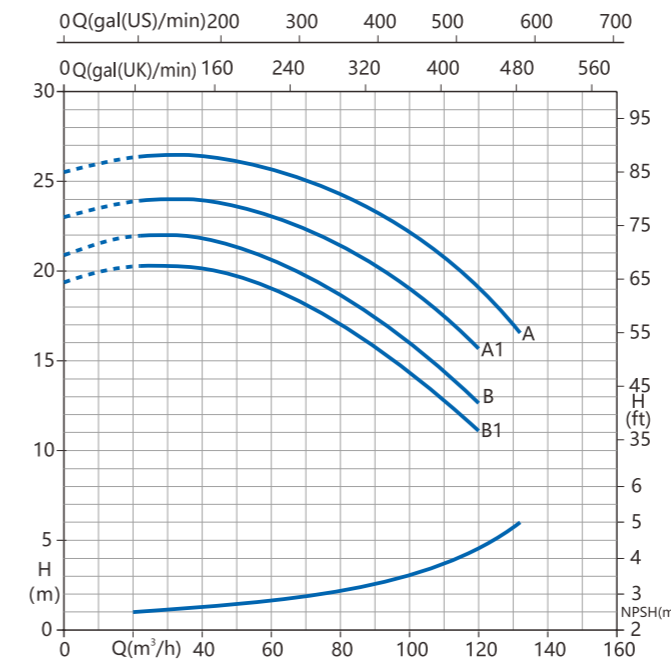

65-160

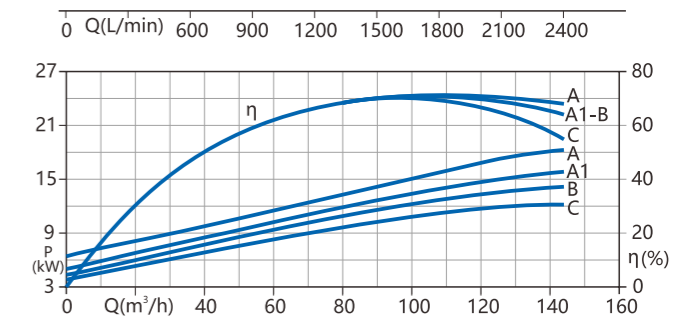
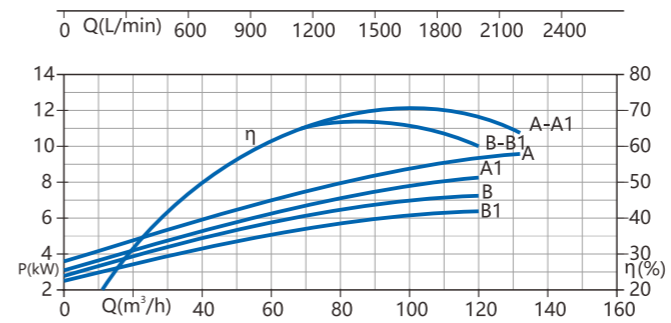
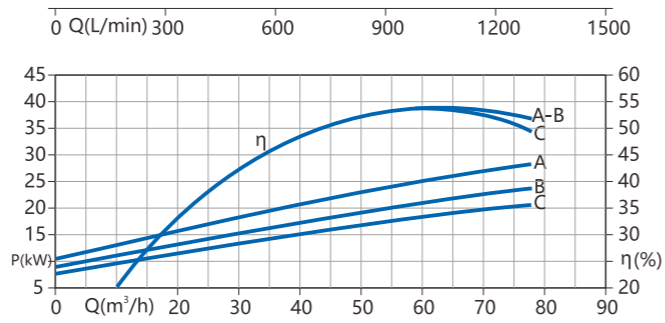
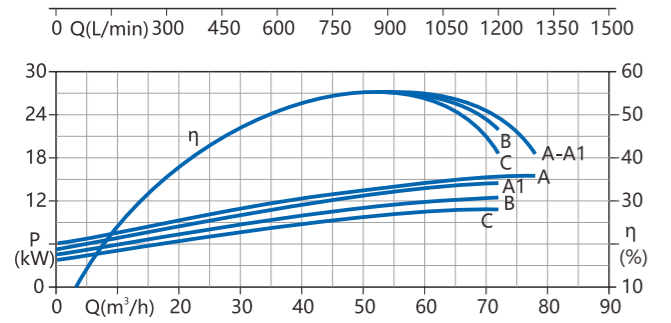
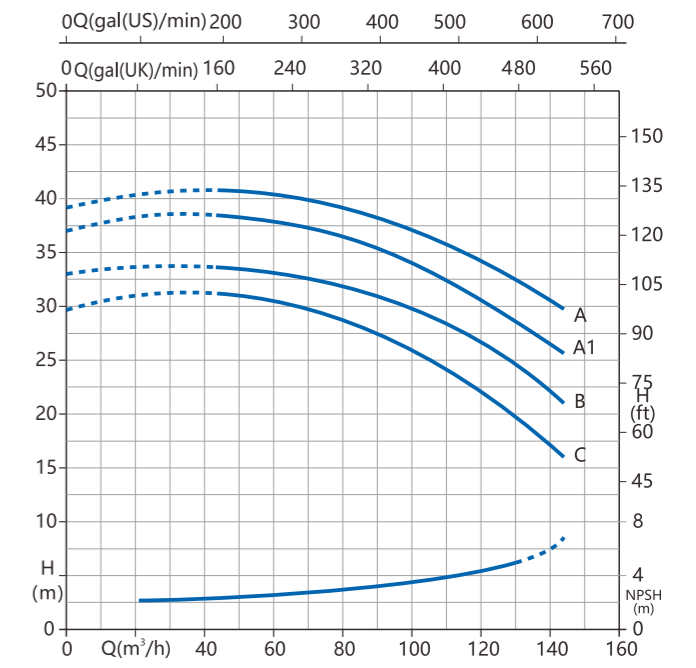

TYPE	P2		P1 (kW)	Q(m³/h-L/min)													
	(HP)	(kW)		3~	0	24	27	30	33	36	39	42	48	54	60	66	72
50-200 C	12.5	9.2	10.8	46	45.6	45.1	44.5	43.7	42.9	41.8	40.8	38.5	35.9	33	29	24.5	--
50-200 B	15	11	12.4	50.8	51	50.5	50	49.3	48.5	47.7	46.8	44.7	42.2	39.5	35.9	32	--
50-200 A1	20	15	14.5	57	57.3	57.1	56.7	56.2	55.96	54.8	54.1	54.1	50.2	47.5	44	40	--
50-200 A	20	15	15.4	58	58.3	58	57.5	57.5	56.4	55.7	55	53.2	51.3	49	46.3	42.8	38.8

Other voltages and frequencies available on request.

TYPE	P2		P1 (kW)	Q(m³/h-L/min)																	
	(HP)	(kW)		3~	0	30	33	36	39	42	48	54	60	66	72	78	84	96	108	120	132
65-125 B1	7.5	5.5	6.4	19.4	20.4	20.4	20.3	20.2	20.1	19.8	19.4	19	18.5	17.9	17.2	16.5	15	13.3	11.1	--	
65-125 B	7.5	5.5	7.2	20.9	22	22	21.9	21.8	21.7	21.4	21	20.6	20.1	19.6	19	18.3	16.6	14.7	12.6	--	
65-125 A1	10	7.5	8.1	23	24.1	24.1	24	23.9	23.8	23.6	23.3	23	22.7	22.3	21.8	21.2	19.7	17.8	15.7	--	
65-125 A	10	7.5	9.5	25.4	26.4	26.4	26.4	26.3	26.3	26.1	25.9	25.6	25.3	24.9	24.5	24	22.7	21	18.9	16.5	

Other voltages and frequencies available on request.

TYPE	P2		P1 (kW)	Q(m³/h-L/min)													
	(HP)	(kW)		3~	0	27	30	33	36	39	42	48	54	60	66	72	78
50-250 C	20	15	20	71.5	70.8	70.3	69.7	69	68.3	67.6	66	64	61.5	58.6	55	50.5	--
50-250 B	25	18.5	23	78	78	77.4	76.8	76.1	75.3	74.5	72.8	70.6	68.2	65.5	62.2	58.3	--
50-250 A	30	22.5	28.5	90	89.5	88.8	88.3	87.7	86.9	86.1	84.5	82.7	80.5	78	75.2	71.7	--

Other voltages and frequencies available on request.

TYPE	P2		P1 (kW)	Q(m³/h-L/min)																	
	(HP)	(kW)		3~	0	42	48	54	60	66	72	78	84	96	108	120	132	144			
65-160 C	12.5	9.2	11.7	29.8	31.2	31.1	30.8	30.5	30.1	29.6	29	28.3	26.6	24.6	22.1	19.3	16	--			
65-160 B	15	11	13	33	34.6	34.4	34.2	34	33.7	33.3	32.8	32.1	30.6	28.8	26.7	24.1	21.1	--			
65-160 A1	20	15	15.8	37.1	38.5	38.3	38.1	37.8	37.5	37.1	36.7	36.1	34.6	32.8	30.7	28.4	25.7	--			
65-160 A	20	15	18	39.2	40.6	40.6	40.4	40.2	40	39.7	39.4	38.9	37.7	36.2	34.3	32.2	29.8	--			

Other voltages and frequencies available on request.



65-200

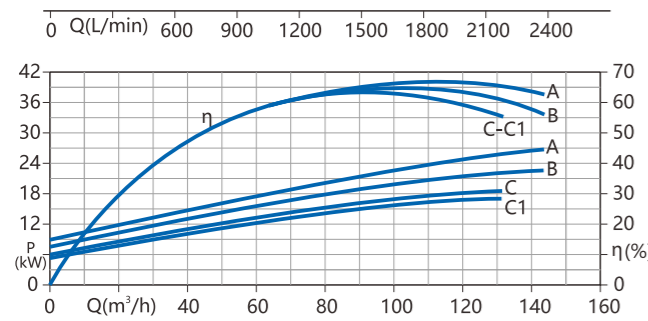
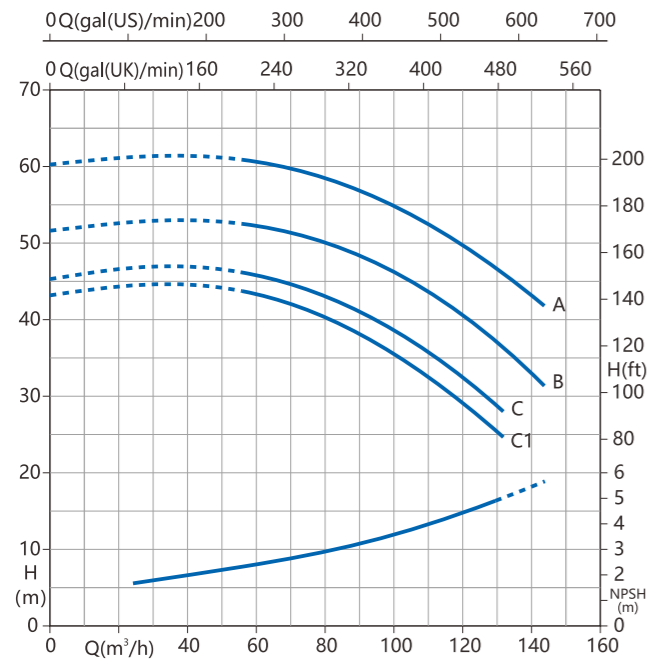

60-250

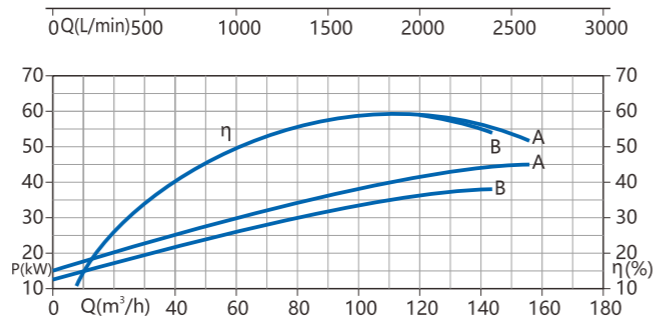
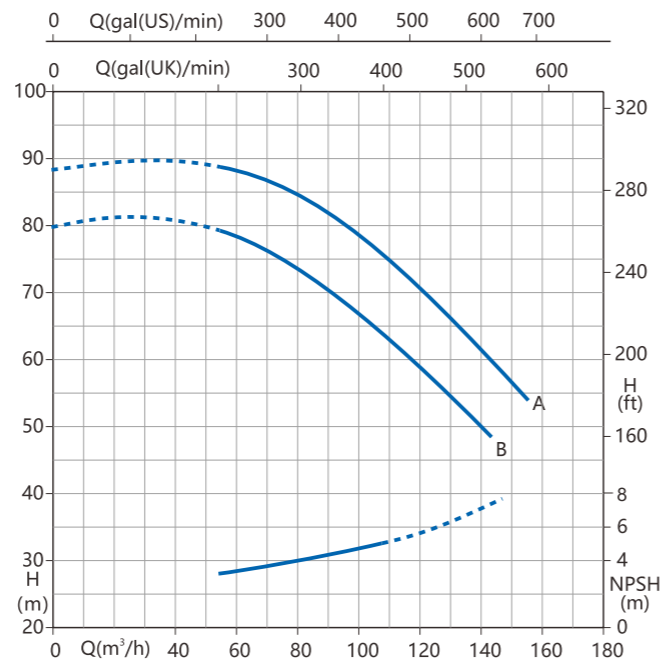

80-160

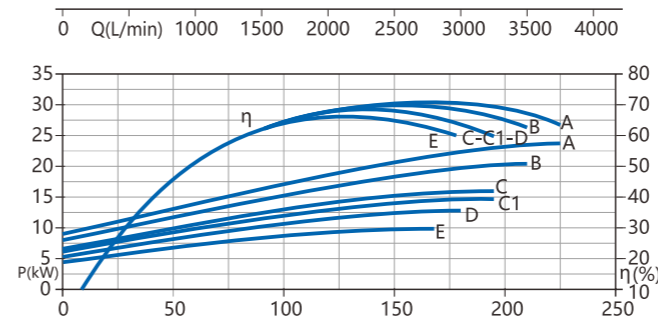
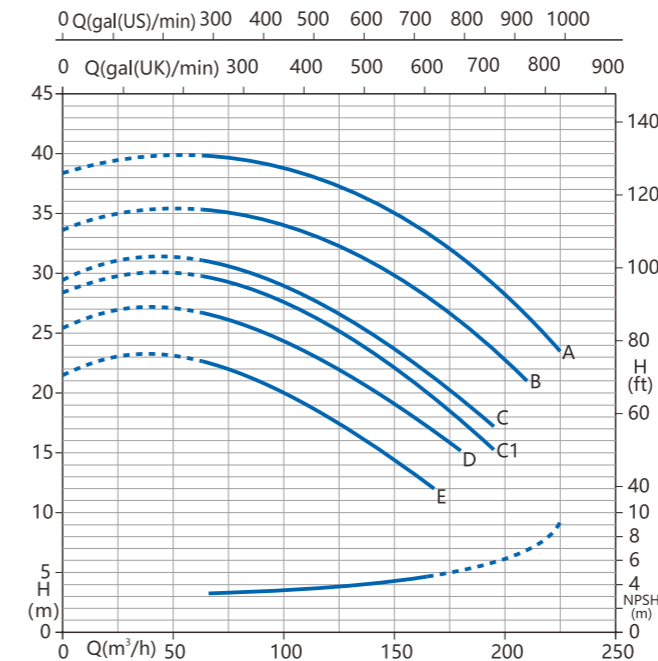

80-200

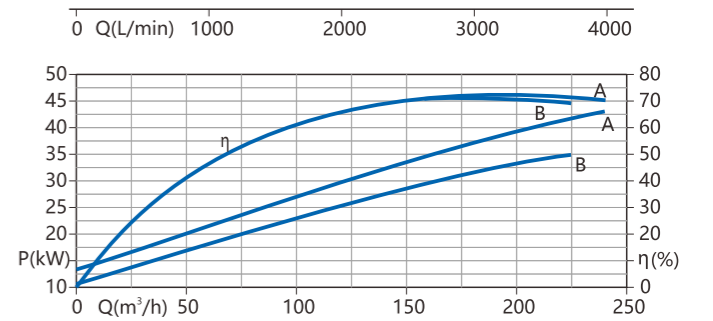
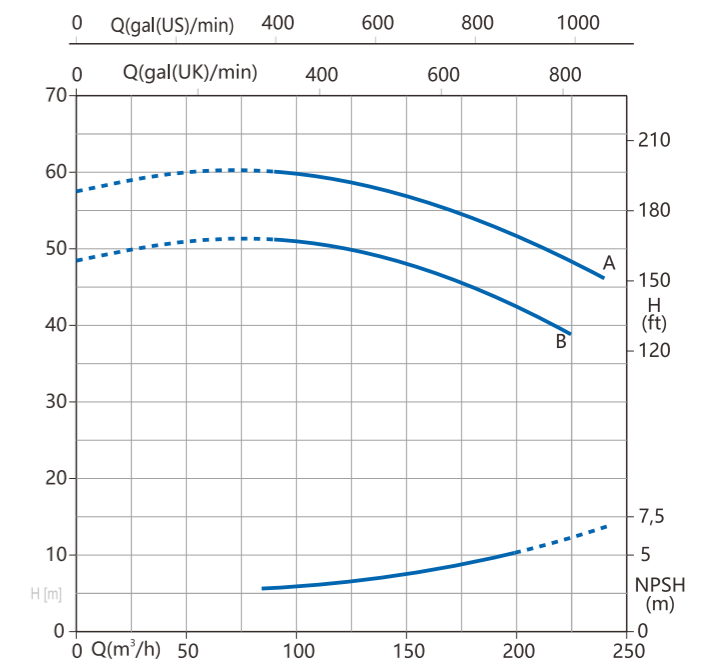

TYPE	P2		P1 (kW)	Q(m³/h-L/min)											
	(HP)	(kW)		3~	0	54	60	66	72	78	84	96	108	120	132
65-200 C1	20	15	17.1	43.1	43.8	43.2	42.5	41.7	40.6	39.5	36.8	33.4	29.3	24.5	--
65-200 C	20	15	18.6	45.3	46.3	45.7	45.1	44.3	43.4	42.3	39.8	36.7	32.7	28	--
65-200 B	25	18.5	22.6	51.6	52.6	52.2	51.8	51	50.2	49.3	47.1	44.1	40.9	36.6	31.3
65-200 A	30	22.5	26.6	60.2	61	60.6	60.1	59.5	58.7	57.8	55.8	53.1	49.8	46.1	41.7

Other voltages and frequencies available on request.

TYPE	P2		P1 (kW)	Q(m³/h-L/min)												
	(HP)	(kW)		3~	0	54	60	66	72	78	84	96	108	120	132	144
65-250 B	40	30	37.8	81	79.5	78.5	77.3	76	74.5	73	69.3	65	60	54.5	48.5	--
65-250 A	50	37	45	90	89.5	88.5	87.5	86.5	85.5	84	80.5	76.5	72	66.5	60.5	54

Other voltages and frequencies available on request.

TYPE	P2		P1 (kW)	Q(m³/h-L/min)																	
	(HP)	(kW)		3~	0	66	72	78	84	96	108	120	132	144	156	168	180	195	210	225	
80-160 E	12.5	9.2	9.9	21.4	22.4	22.1	21.6	21.2	20.2	19.2	18	16.8	15.4	13.7	12	--	--	--	--		
80-160 D	15	11	12.7	25.4	26.4	26.1	25.7	25.3	24.4	23.6	22.5	21.3	20	18.5	16.9	15.1	--	--	--		
80-160 C1	20	15	14.8	28.5	29.5	29.3	29	28.6	27.8	26.9	25.7	24.6	23.3	21.7	19.9	17.9	15.2	--	--		
80-160 C	20	15	15.9	29.7	30.7	30.5	30.3	29.9	29.2	28.1	27.1	26	24.7	23.1	21.5	19.7	17.2	--	--		
80-160 B	25	18.5	20.1	34	35	35	34.8	34.6	34	33.3	32.5	31.6	30.5	29.2	27.8	26	23.6	21	--		
80-160 A	30	22.5	23.7	38.8	39.8	39.7	39.6	39.4	38.9	38.2	37.5	36.7	35.7	34.5	33.2	31.6	29.4	26.8	23.5		

Other voltages and frequencies available on request.

TYPE	P2		P1 (kW)	Q(m³/h-L/min)															
	(HP)	(kW)		3~	0	84	96	108	120	132	144	156	168	180	195	210	225	240	
80-200 B	40	30	37.8	49	50.8	50.6	50.3	49.8	49.3	48.6	47.7	46.7	45.5	44.8	41.6	38.6	--		
80-200 A	50	37	45	58	--	59.6	59.2	58.6	58	57.3	56.4	55.5	54.3	52.7	50.8	48.5	46.1		

Other voltages and frequencies available on request.



Dimension					
DN	øK	øK1	N	øD	
32	140	100	4	18	
40	150	110	4	18	
50	165	125	4	18	
65	185	145	4	18	
80	200	160	8	18	
100	220	180	8	18	

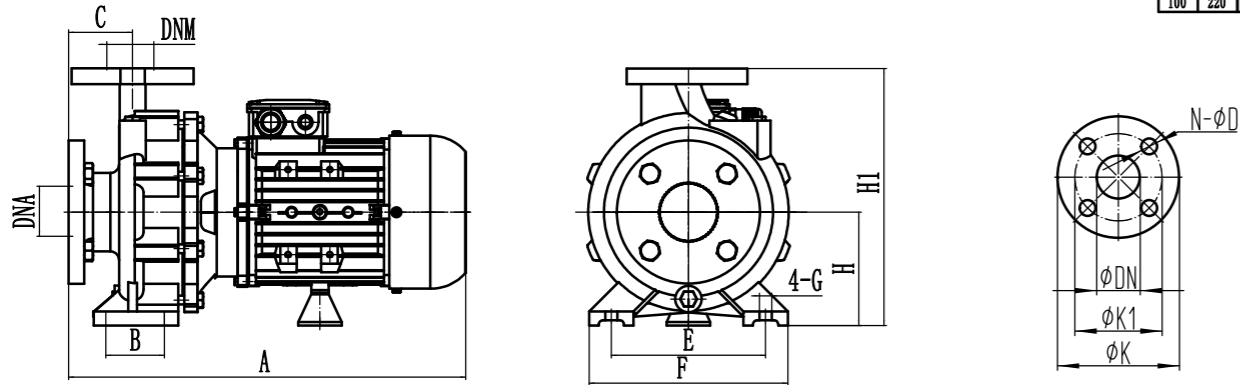

Model	Power		DNA	DNM	A	B	C	E	F	H	H1	G	Weight Kg
	KW	HP											
CM32-160C	1.5	2	50	32	455	72	82	190	240	132	292	16	
CM32-160B	2.2	3	50	32	480	72	82	190	240	132	292	16	
CM32-160A	3	4	50	32	500	72	82	190	240	132	292	16	
CM32-200C	4	5.5	50	32	550	72	100	214	266	160	340	16	
CM32-200B	5.5	7.5	50	32	580	72	100	214	266	160	340	16	
CM32-200A	7.5	10	50	32	580	72	100	214	266	160	340	16	
CM32-250E	5.5	7.5	50	32	580	85	95	250	327	185	405	16	
CM32-250D	7.5	10	50	32	580	85	95	250	327	185	405	16	
CM32-250C	9.2	12.5	50	32	620	85	95	250	327	185	405	16	
CM32-250B	11	15	50	32	680	85	95	250	327	185	405	16	
CM32-250A	15	20	50	32	680	85	95	250	327	185	405	16	
CM40-125C	1.5	2	65	40	430	70	80	160	210	112	252	15	
CM40-125B	2.2	3	65	40	455	70	80	160	210	112	252	15	
CM40-160B	3	4	65	40	500	72	82	190	242	132	292	16	
CM40-160A	4	5.5	65	40	535	72	82	190	242	132	292	16	
CM40-200B	5.5	7.5	65	40	580	72	100	214	266	160	341	16	
CM40-200A	7.5	10	65	40	580	72	100	214	266	160	341	16	
CM40-250C	9.2	12.5	65	40	621	95	102	250	325	180	405	16	
CM40-250B	11	15	65	40	685	95	102	250	325	180	405	16	
CM40-250A	15	20	65	40	685	95	102	250	325	180	405	16	
CM50-125C	2.2	3	65	50	520	66	100	190	241	132	302	16	
CM50-125B	3	4	65	50	520	66	100	190	241	132	302	16	
CM50-125A	4	5.5	65	50	520	66	100	190	241	132	302	16	
CM50-160B	5.5	7.5	65	50	580	72	100	214	266	160	341	16	
CM50-160A	7.5	10	65	50	580	72	100	214	266	160	341	16	

Dimension					
DN	øK	øK1	N	øD	
32	140	100	4	18	
40	150	110	4	18	
50	165	125	4	18	
65	185	145	4	18	
80	200	160	8	18	
100	220	180	8	18	

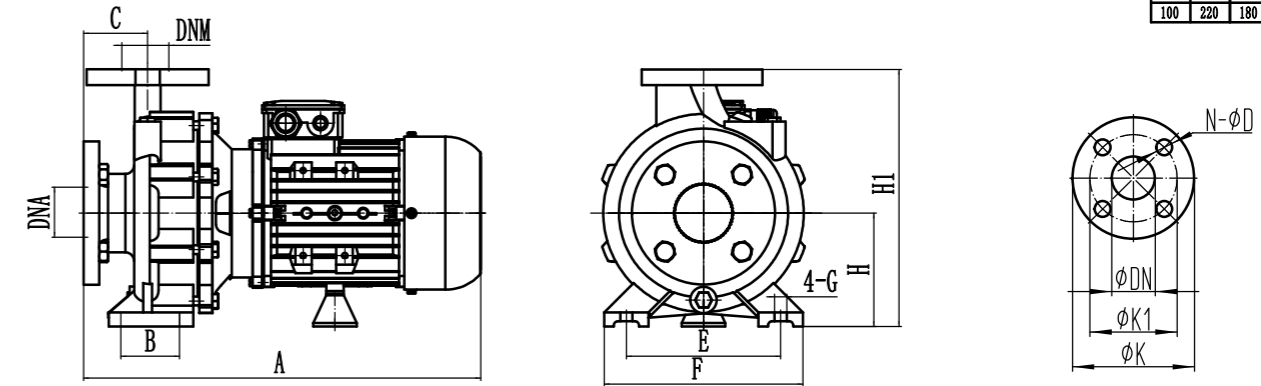

Model	Power		DNA	DNM	A	B	C	E	F	H	H1	G	Weight Kg
	KW	HP											
CM50-200C	9.2	12.5	65	50	630	72	101	214	266	160	362	16	
CM50-200B	11	15	65	50	697	72	101	214	266	160	362	16	
CM50-200A	15	20	65	50	697	72	101	214	266	160	362	16	
CM50-250C	15	20	65	50	690	95	102	250	320	180	405	16	
CM50-250B	18.5	25	65	50	735	95	102	250	320	180	405	16	
CM50-250A	22	30	65	50	735	95	102	250	320	180	405	16	
CM65-125B	5.5	7.5	80	65	590	95	100	212	280	160	340	16	
CM65-125A	7.5	10	80	65	590	95	100	212	280	160	340	16	
CM65-160C	9.2	12.5	80	65	625	95	100	212	282	160	360	16	
CM65-160B	11	15	80	65	690	95	100	212	282	160	360	16	
CM65-160A	15	20	80	65	690	95	100	212	282	160	360	16	
CM65-200C	15	20	80	65	690	95	100	250	320	180	405	16	
CM65-200B	18.5	25	80	65	735	95	100	250	320	180	405	16	
CM65-200A	22	30	80	65	735	95	100	250	320	180	405	16	
CM65-250C	22	30	80	65	735	120	100	280	360	200	450	22	
CM65-250B	30	40	80	65	940	120	100	280	360	200	450	22	
CM65-250A	37	50	80	65	940	120	100	280	360	200	450	22	
CM80-160E	9.2	12.5	100	80	710	92	125	250	320	180	405	14	
CM80-160D	11	15	100	80	710	92	125	250	320	180	405	14	
CM80-160C	15	20	100	80	710	92	125	250	320	180	405	14	
CM80-160B	18.5	25	100	80	755	92	125	250	320	180	405	14	
CM80-160A	22	30	100	80	755	92	125	250	320	180	405	14	
CM80-200C	22	30	100	80	760	96	125	276	346	180	430	14	
CM80-200B	30	40	100	80	975	96	125	276	346	180	430	14	
CM80-200A	37	50	100	80	975	96	125	276	346	180	430	14	