

FCP Series

SWIMMING POOL PUMP

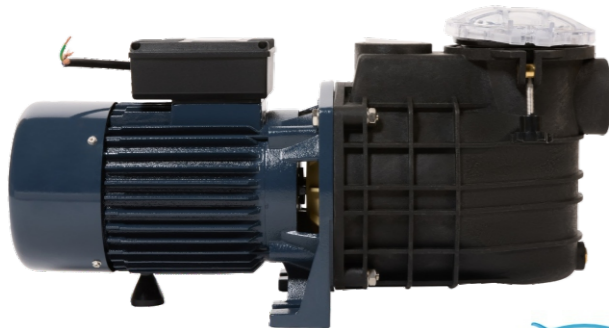

OPERATING CONDITIONS

- Liquid temperature up to 60°C
- Ambient temperature up to 40°C
- Total suction lift up to 9m
- Continuous duty

PUMP

- Pump Body: Techno-polymer
- Impeller: Techno-polymer
- Mechanical Seal: Carbon / Ceramic / Stainless Steel

MOTOR

- Single Phase: IE1, IE2/IE3
- Heavy Duty Continuous Work
- Motor Housing: Aluminum / Cast Iron
- Shaft: Carbon Steel / Stainless Steel
- Insulation: Class B / Class F
- Protection: IP44 / IP54
- Cooling: External Ventilation

IDENTIFICATION CODES

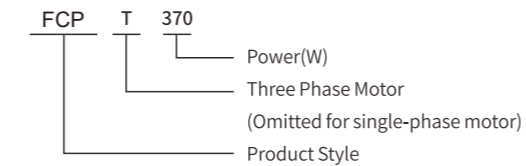

TECHNICAL DATA (220~240V/50Hz)

Model	Single-phase Motor				n=2850r/min			Dimensions (mm)			
	Input max kW	Output Power kW	HP	Current A	Q.max L/min	H.max m	Suct.max m	DNA		DNM	
FCP -370	0.55	0.37	0.50	3.2	190	12		1.5"	40	1.5"	40
FCP -550	0.80	0.55	0.75	3.8	200	14		1.5"	40	1.5"	40
FCP -750	1.10	0.75	1.00	5.2	220	16	9	1.5"	40	1.5"	40
FCP -1100	1.50	1.10	1.50	7.0	300	18		2"	50	2"	50
FCP -1500	2.00	1.50	2.00	9.6	360	19		2"	50	2"	50
FCP -2200	2.90	2.20	3.00	13.9	400	22		2"	50	2"	50

Other voltages and frequencies available on request.

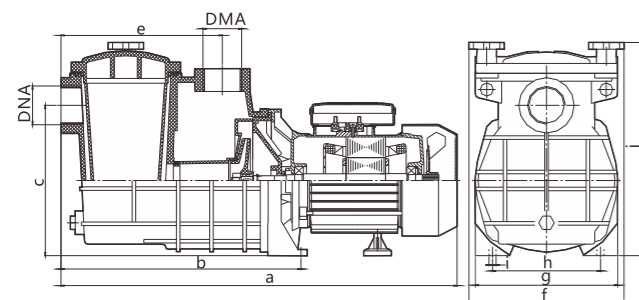

OVERALL & INSTALLATION DIMENSIONS

Model	Dimensions (mm)								
	a	b	c	d	e	f	g	h	i
FCP -370	500	304	190	--	204	196	180	136.5	9
FCP -550	500	304	190	--	204	196	180	136.5	9
FCP -750	500	304	190	--	204	196	180	136.5	9
FCP -1100	500	304	190	--	204	196	180	136.5	9
FCP -1500	500	304	190	--	204	196	180	136.5	9
FCP -2200	585	320	206	--	224	220	218	153	16

MATERIALS TABLE

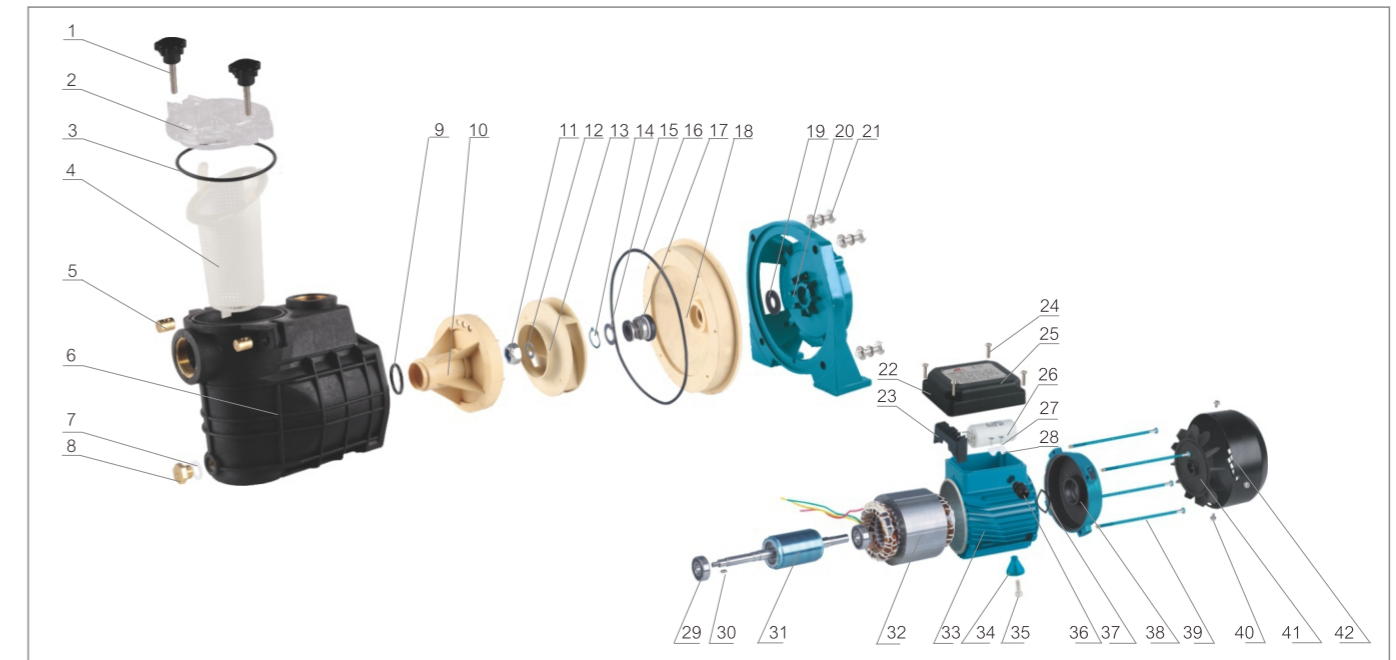

HYDRAULIC PERFORMANCE CURVES

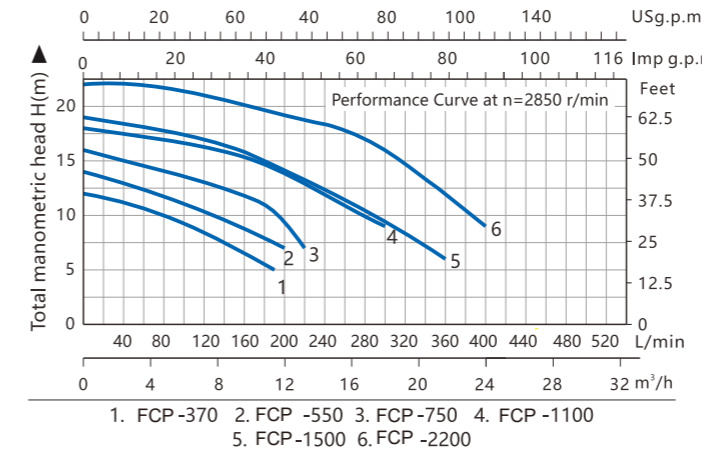

NO.	DESCRIPTION	NO.	DESCRIPTION	NO.	DESCRIPTION
1	Plastic Cap Screw	18	M-Seal Holding Disc	35	Screw For Motor Foot
2	Plastic Cap	19	Splash Guard	36	Cable Gland
3	"O" Ring	20	Front Cover	37	Adjusting Ring
4	Filter	21	Front Cover Screw	38	Motor End Cover
5	Dowel	22	Terminal Cover	39	Motor Tie-Rod
6	Pump Body	23	Terminal Block	40	Screw For Fan Cover
7	Drain Plug	24	Screw For Terminal Box	41	Fan
8	"O" Ring for drain plug	25	Nameplate	42	Fan Cover
9	"O" Ring	26	Capacitor		
10	Diffuser	27	Screw For Cable Presser		
11	Impeller Nut	28	Cable Presser		
12	Plain Washer	29	Ball Bearing		
13	Impeller	30	Key		
14	Circlip	31	Shaft And Rotor		
15	Plain Washer	32	Stator With Casing		
16	"O" Ring For Pump Body	33	Motor Case		
17	Mechanical Seal	34	Motor Foot		

PACKAGE INFORMATION

Model	Package dimensions & G.W. (mm)				MOQ
	L	W	H	kg	Kraft carton pcs
FCP -370	530	220	300	7.5	300
FCP -550	530	220	300	9	200
FCP -750	530	220	300	10.5	200
FCP -1100	640	240	300	17.5	100
FCP -1500	640	240	300	19.0	100
FCP -2200	660	240	300	20.5	50

