

ISC Series

SELF-PRIMING CENTRIFUGAL PUMP



OPERATING CONDITIONS

- Liquid temperature up to 40°C
- Ambient temperature up to 40°C
- Submersion depth 5m
- Continuous duty

PUMP

- Pump Body: Cast Iron
- Impeller: cast iron
- Mechanical Seal: Carbon / Ceramic / Stainless Steel

MOTOR

- Built-in overload motor protector with automatic reset
- Motor efficiency: IE1, IE2/IE3
- Permanent split capacitor
- Insulation: Class F
- Protection: IPX4
- Shaft: AISI304/AISI420/AISI1045

ADVANTAGES & FEATURES

- Self-priming
- Able to drain infiltrating water, cellars or reservoirs, clean or slightly dirty water and for garden irrigation.
- Built-in check valve prevent siphon effect when stopping and ensure re-starting each time.

IDENTIFICATION CODES

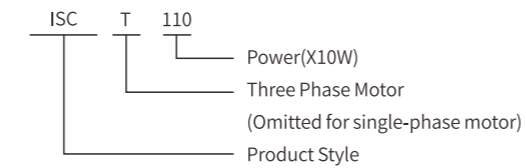

TECHNICAL DATA(220~230V/60Hz)

Type		Nominal Power		Input Power	Q = capacity											
Single-phase	Three-phase	P2		P1	Total head in meters w.c.											
230V-50Hz	230/400V-50Hz	HP	kW	kW	m ³ /h	3	6	12	18	24	36	48	60	72	84	96
					lt/1'	50	100	200	300	400	600	800	1000	1200	1400	1600
ISC110	ISCT110	1.5	1.1	1.8	18.5	18	16	13.5	10.5	-	-	-	-	-	-	-
ISC150	ISCT150	2	1.5	2.1	18.5	17	15	12	4	-	-	-	-	-	-	-
ISC220	ISCT220	3	2.2	3.3			15	14	13	11	6	-	-	-	-	-
-	ISCT400	5.5	4	5.7			24	23	22	21	19	17	14	11	-	-
-	ISCT550	7.5	5.5	8.5			26.5	26	25	24	22.5	21	19	16.5	-	-

Other voltages and frequencies available on request.

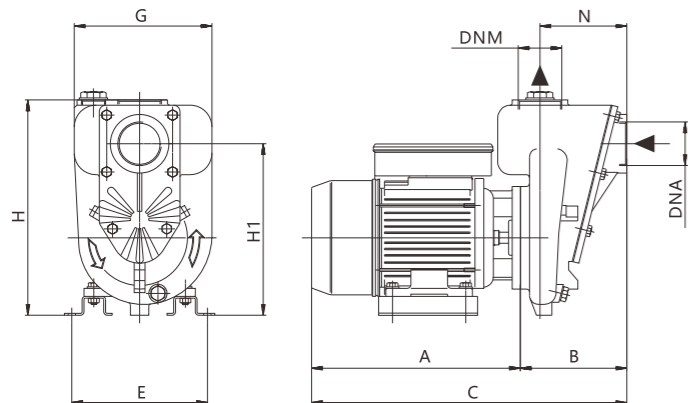

OVERALL & INSTALLATION DIMENSIONS

Model		Dimensions (mm)								
Single phase	Three phase	DNA	DNM	C	E	G	H	H1	N	
ISC110	ISCT110	2"	2"	412	185	193	302	240	122	
ISC150	ISCT150	2"	2"	412	185	193	302	240	122	
ISC220	ISCT220	3"	3"	528	200	193	312	220	150	
-	ISCT400	3"	3"	648	185	280	442	348	185	
-	ISCT550	3"	3"	705	210	280	465	373	185	

MATERIALS TABLE

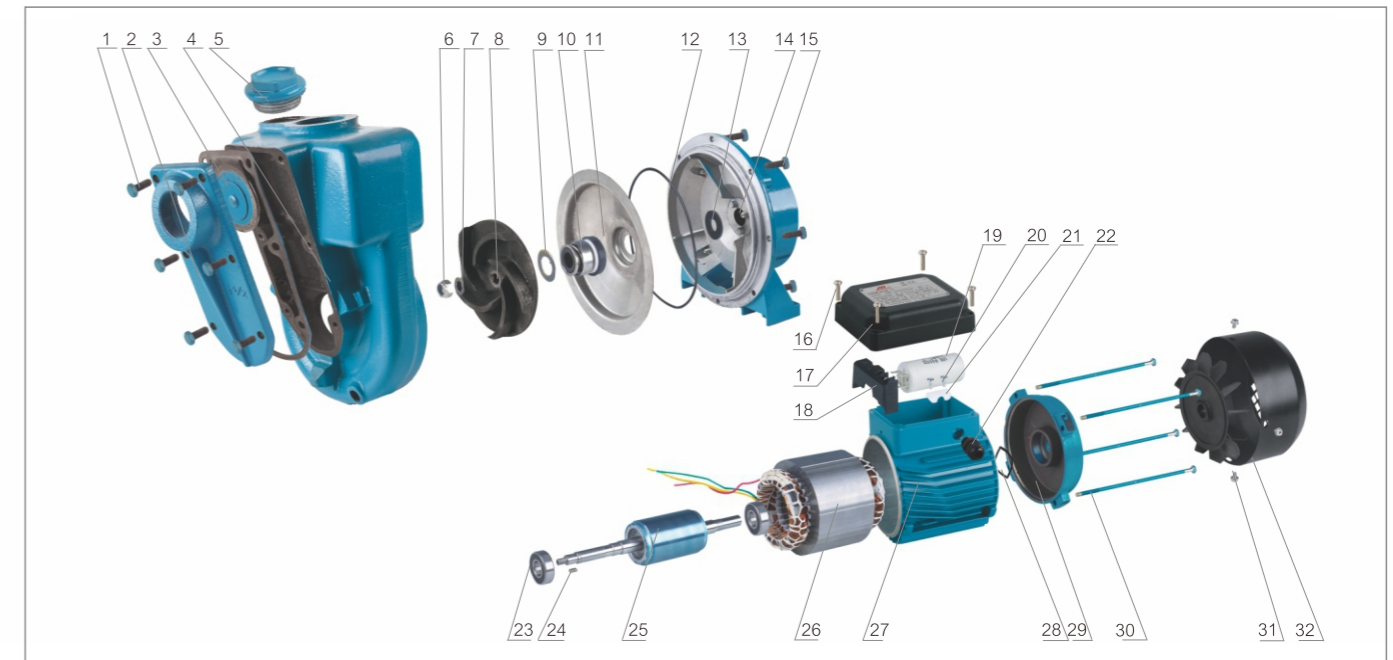

HYDRAULIC PERFORMANCE CURVES

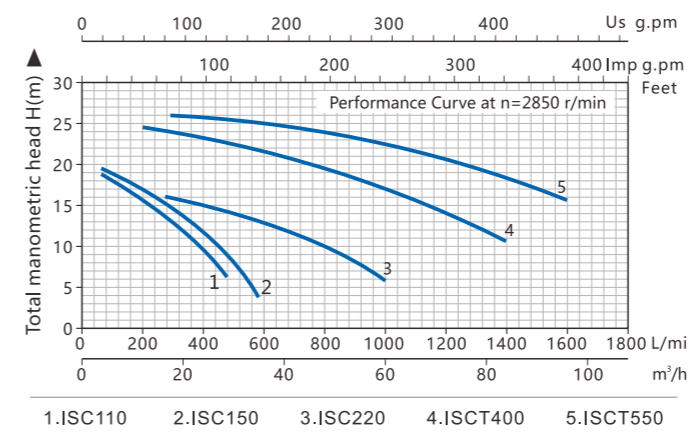

NO.	DESCRIPTION	NO.	DESCRIPTION
1	Hex Bolt For Flange	18	Terminal Block
2	Flange	19	Capacitor
3	Gasket	20	Screw For Cable Presser
4	Pump Body	21	Cable Presser
5	Filling Plug	22	Cable Gland
6	Impeller Stop Nut	23	Bearing
7	Plain Washer	24	Key
8	Impeller	25	Rotor With Shaft
9	Plain Washer	26	Stator With Winding
10	Mechanical Seal	27	Motor Housing
11	M-seal Holding Disc	28	Adjusting Ring
12	O-ring For Pump Body	29	Rear Cover
13	Splash Guard	30	Motor Tie-rod
14	Motor Bracket	31	Fan
15	Hex Bolt For Pump Body	32	Fan Cover
16	Screw For T-box		
17	Terminal Box		

PACKAGE INFORMATION

Model		Package dimensions & G.W. (mm)				MOQ
Single phase	Three phase	L	W	H	kg	Kraft carton pcs
ISC110	ISCT110	420	220	330	26	100
ISC150	ISCT150	420	220	330	28	100
ISC220	ISCT220	420	220	330	36	100
-	ISCT400	655	490	360	71	100
-	ISCT550	730	490	360	92	100

