



DAVE-PUMP

“Till Last Drop”



JKRB - JKRX - JKRN- DAVE GEAR PUMP CAST IRON FLANGE TYPE

Mfgd. By :

APEX PUMP APEX GEAR PUMP LTD
71-75 Shelton Street, London WC2H
9JQ UK

ADVANCED TECHNOLOGY FOR PUMPING VISCOUS LIQUID

PUMP CHARACTERISTIC

Gear pump is a rotary positive displacement pump with positive pressure characteristic. The capacity of the pump varies directly with speed but remain constant against pressure, however due to running clearance between the casing & impeller some liquid always passes to suction causing sleep, which depends upon the differential pressure, viscosity of the liquid & ofcourse the workman-ship. The pumps are capable of handling any viscosity, the sleep reduces with viscosity but the viscous power increases. The pump has a self priming capability however some net positive suction head (NPSH) is always required to avoid cavitations depending upon the viscosity of the liquid to be pumped & the pump speed.

INTERNAL POWER LOSSES

The power losses in rotary pumps are of two types. The mechanical losses is the power necessary to overcome frictional drag of all the moving part within the pump while viscous losses is power required to overcome fluid viscous drag & shearing action of the fluid, this can be computed from the graph on the opposite side.

H.P. CALCULATION

The break horse power required to drive a rotary pump is sum of the theoretical HP & internal power losses. The theoretical horse power is the actual work done in moving the fluid from inlet port to out let pressure condition & is product of Constant C=0.037(capacity-LPM, Pressure kg/cm²) or C=2.3(capacity-GPM, pressure PSI)

PUMP SELECTION & USES

The bush bearing type of pump can be used for clean viscous liquid having sufficient lubricating value such as clean lube oil, Vegetable oil, Fish & Animal oil, Gear oil, Glycerine, Hydraulic oil, Honey, ASTM & SAE lubricating oil for intermitting duty. However for continues duty pump with needle roller bearing in “JKRN” series should be selected. For liquid having low viscosity, poor lubricating values or Containing dirts or impurities such as Crude oil, Dirty lube oil, HSD, Kerosene, LDO, Paints, Sugar solution, Turpentine, Varnish, Wood Plup, Pump with indpendently lubricated bearing should be selected. For liquid which tends to solidify at room temperature such as Ashphalt, Bituman, Furnace oil, Tar, Cellulose, Starch, LSHS, HPS, Molasses, Naptha, Phenol resin, RFO, Silicate, Soap solution, Viscous, Wax etc. Jacketing construction should be selected to facilitate the heating or the pump by steam or thermic fluid.

INSPECTION & TESTING

All Pumps are individually tested for its performance as per JIS B-8312-1976.

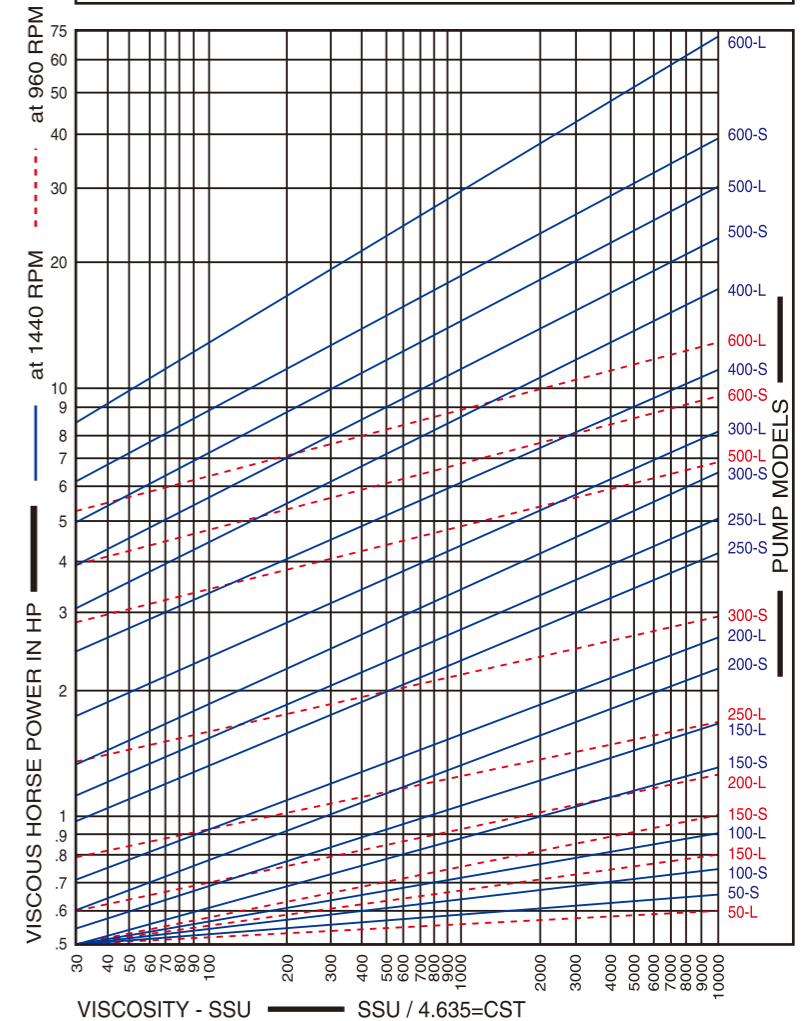
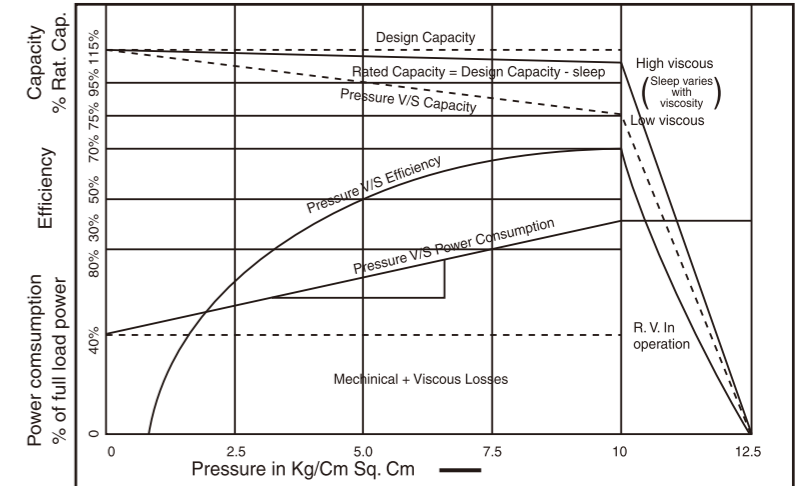

* All dimensions are in millimeters. Unless otherwise stated, Specifications are subject to change without prior notice as improvements are made from time to time.

Mfgd. By :

APEX PUMP APEX GEAR PUMP LTD
71-75 Shelton Street, London WC2H
9JQ UK

Dealers :

ADVANCED TECHNOLOGY FOR PUMPING VISCOUS LIQUID

Proven performance & operational economy are prime consideration while evaluating your pumping requirement. When it comes to handling viscous or semi viscous liquids "DAVE PUMP" rotary gear pump is an obvious choice for the very reasons.

"DAVE PUMP" rotary gear, twin gear & screw-gear pumps are wellknown, widely accepted DAVE PUMP pumps in all the industries for it's efficient performance, operational reliability, compact design & noiseless operation. These pumps have outclassed conventional gear pump & has also broken myth about screw pump offering better overall performance at considerable reduced cost. Many imported gear & screw pump offering better overall performance at considerable reduced cost. Many imported gear & screw pumps are replaced with "DAVE PUMP" pumps in power stations, steel plants, refineries, oil installation on navy vessels & cargo ship, Popular range of "JKRN" series

"DAVE PUMP" rotary screw-gear pumps are redesigned & re-engineered to offer further simplicity with added reliability meeting international standard like API, J1S, DIN & above all, the growing expectations of enlightened customers.

"DAVE PUMP" series twin gear pump now offer enlarged capacity range with option of self or independently lubricated jacketed or non-jacketed construction with all sizes designed to run at synchronous speed of 4-pole primeover to further reduce the overall cost of the pump set. It will be a wise decision to go for "DAVE PUMP" rotary twin gear pump even if it amounts to scrapping existing pump at your present installation.

ADVANTAGES

- Herrigbone rotors design eliminate side thrust.
- Modified tooth profile enhances the tooth life.
- Floating gear-design ensures uniform load distribution.
- Low-leakage path by design improve volumetric efficiency.
- Extra thick shaft reduces bending effectively.
- Sleeve on shaft make maintenance economical & easy.

PARTS LIST WITH MATERIAL OF CONSTRUCTION							
SR.	ITEM	QT.	MATERIAL	SR.	ITEM	QT.	MATERIAL
01	PUMP CASING	1	CI/CS/SS	12	R.V. PISTON	1	EN-8/SS
02	FRONT COVER	1	CI/CS/SS	13	R.V. SPRING	1	SPR. ST
03	BACK COVER	1	CI/CS/SS	14	R.V.AD. SCREW	1	EN-8/SS
04	GLAND COVER	1	CI/CS/SS	15	BASE PLATE	1	M.S.
05	ROTARY SHAFT	1	EN-9/19/SS	16	COUP. GUARD	1	ALUMIN.
06	STATOR SHAFT	1	EN-9/19/SS	17	COUPLING	1	FLEXIBLE
07	IMPELLER GEAR	1	EN-24/SS	18	COUP. KEY	1	EN-8/SS
08	NEEDLE BRG.	4	INA/IKO	19	SEALING SYS.	2	OS/MS/GP
09	WEAR PLATE	4	Bronze	20	DOWEL PIN	4	SILV. ST
10	LIFTING HOOK	4	Steel	21	COMP. FLANGE	2	MS/SS
11	R.V. HOUSING	1	MAL./RON	22	H/T HEX-BOLT	12	EN-8/SS

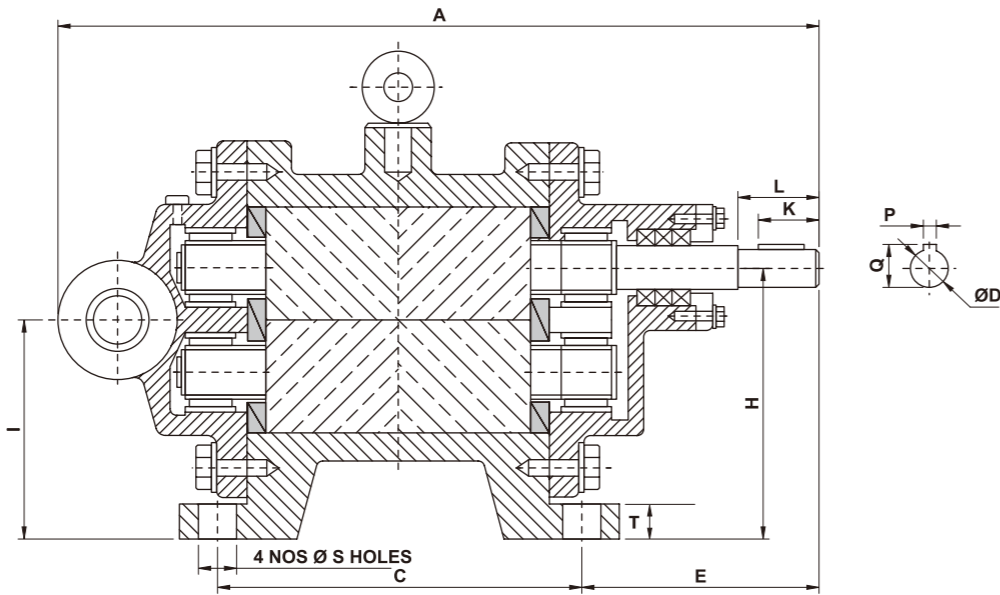

ADVANCED TECHNOLOGY FOR PUMPING VISCOUS LIQUID

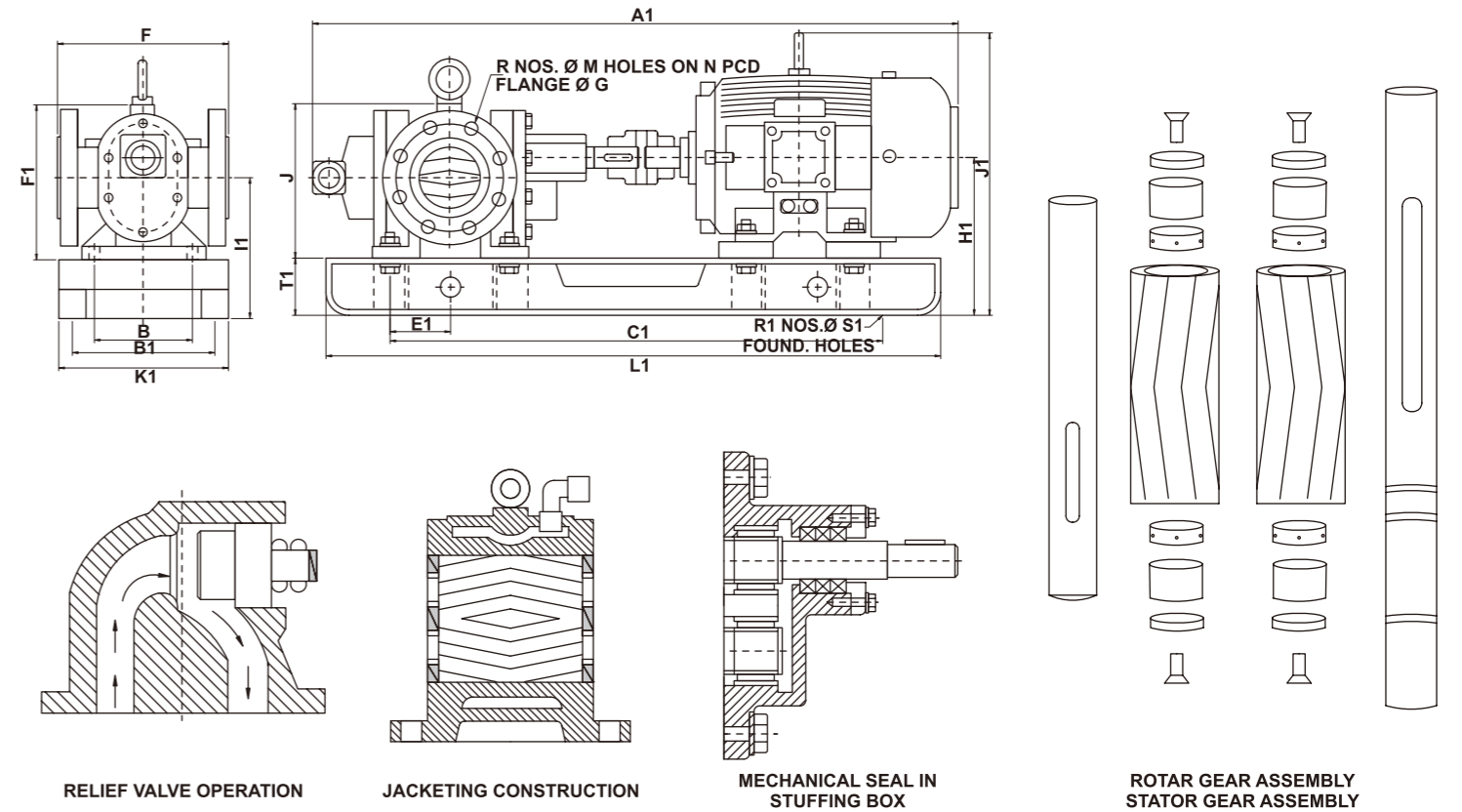

AVAILABLE MODEL SIZE & CAPACITY						
SIZE & MODEL	1750 RPM CAPACITY			PUMP GD 2 IN KGM2	ELE MOTER H.P	FR. SIZE
	LPM	US GPM	M3/HR			
1/2"	08.30	02.20	0.50	0.0008	0.50	71M
50	16.60	04.40	1.00	0.0009	0.75	80M
S-M-L	25.00	06.60	1.50	0.0010	1.00	80M
1"	33.30	08.80	2.00	0.0007	0.75	80M
100	50.00	13.20	3.00	0.0008	1.00	80M
S-M-L	60.00	15.84	3.60	0.0009	2.00	90L
1 1/2"	83.30	22.00	5.00	0.0008	2.00	90L
150	100.00	26.40	6.00	0.0009	3.00	100L
S-M-L	125.00	33.30	7.50	0.0032	5.00	112M
2"	150.00	39.00	9.00	0.0068	3.00	100L
200	166.00	44.00	10.00	0.0074	5.00	112M
S-M-L	200.00	52.80	12.00	0.008	7.50	132S
2 1/2"	250.00	66.00	15.00	0.01	5.00	112M
250	299.88	79.20	18.00	0.013	7.50	132S
S-M-L	333.30	88.00	20.00	0.015	10.00	132M
3"	415.00	105.00	25.00	0.02	10.00	132M
300	449.82	118.00	27.00	0.024	12.50	160M
S-M-L	500.00	132.00	30.00	0.027	15.00	160M
4"	599.76	158.40	36.00	0.056	15.00	160M
400	666.66	176.00	40.00	0.062	20.00	160L
S-M-L	833.30	220.00	50.00	0.072	25.00	180M
5"	1000.00	264.00	60.00	0.098	20.00	160L
500	1250.00	330.00	75.00	0.112	30.00	180L
S-M-L	1499.00	396.00	90.00	0.177	40.00	200L
6"	1660.00	440.00	100.00	0.27	30.00	180L
600	1832.00	484.00	110.00	0.31	50.00	225S
S-M-L	2083.00	550.00	125.00	0.335	60.00	225M
6"	2499.00	660.00	160.00	0.4561	50.00	225S
600	2915.50	770.00	175.00	0.542	75.00	280M
S-M-L	3332.00	880.00	200.00	0.601	100.00	280S

DIEMENSIONS																						WEIGHT BP-COU PUMP BP-COU IN KG.
OVERALL						MOUNTING						SHAFT			FLANGE							
A1	J A	J1	L1	K1	F1	B C	S S1	E F	H I	H1	T1 T	E1	C1	B1	I1	D R1	K L	P Q	M N	G R		
503	122	262	500	145	125	80	8	91	80	158	75	37	340	112	147	11.5	22	4	16	89	11.5	
538	-	283	525	170	130	-	-	-	-	163	-	36	365	125	152	-	-	-	-	-	8.0	
538	239	283	525	170	130	100	15	150	69	163	10	36	365	125	152	40	30	13	60	4	12.0	
570	136	288	600	145	139	90	10	100	90	168	75	26	360	120	152	15	25	5	16	108	12.2	
570	-	288	600	145	139	-	-	-	-	168	-	26	360	120	152	-	-	-	-	-	14.1	
620	271	315	650	180	146	110	15	160	74	175	10	26	410	140	159	4	30	17	79	4	13.1	
667	160	320	625	165	165	105	10	119	100	180	75	30	375	130	160	21	25	6	16	127	14.0	
697	-	328	750	205	163	-	-	-	-	178	-	30	500	170	158	-	-	-	-	-	22.5	
742	318	353	750	230	175	130	15	180	80	190	12	26	500	190	170	4	40	23.5	98	4	18.0	
738	174	340	775	210	177	110	12	133	112	190	75	50	525	170	168	24	39	8	19	152	17.5	
783	-	353	800	230	177	-	-	-	-	190	-	65	550	190	168	-	-	-	-	-	28.0	
853	359	398	850	256	197	150	15	200	90	210	14	50	600	216	188	4	50	27	121	4	20.8	
842	200	377	800	240	203	130	15	163	132	214	75	35	550	205	184	27	40	8	19	178	18.5	
913	-	398	900	255	203	-	-	-	-	210	-	50	650	216	184	-	-	-	-	-	43.0	
953	419	398	950	255	203	160	15	220	106	210	15	50	700	216	184	4	55	30	140	4	22.5	
1015	240	451	1050	287	243	160	18	168	160	263	100	84	750	240	234	32	49	10	19	190	22.0	
1112	-	528	1100	304	243	-	-	-	-	263	-	75	800	254	234	-	-	-	-	-	59.0	
1113	481	528	1100	304	243	220	19	240	131	263	22	75	800	254	234	4	60	35	152	4	33.0	
1186	274	548	1200	315	277	180	18	189	180	283	100	58	800	265	248	37	54	10	19	229	40.0	
1231	-	548	1250	310	277	-	-	-	-	283	-	58	900	254	248	-	-	-	-	-	82.0	
1296	554	568	1300	330	277	270	19	280	145	283	25	90	900	279	248	4	65	40	190	8	47.2	
1292	293	603	1350	300	306	200	19	215	200	338	125	55	950	254	298	47	60	14	22	254	58.0	
1357	-	313	1400	365	296	-	-	-	-	328	-	125	1000	300	288	-	-	-	-	-	150.0	
1447	615	673	1400	380	296	280	22	300	160	328	25	116	1000	318	288	4	85	50.5	216	8	50.5	
1432	343	643	1500	305	351	220	20	215	225	358	150	183	1100	245	311	52	80	16	22	279	50.5	
1608	-	728	1650	420	346	-	-	-	-	353	-	137	1150	356	306	-	-	-	-	-	175.0	
1608	690	728	1650	420	346	350	22	340	178	353	25	137	1150	356	306	4	95	56	241	8	76.0	
1667	357	778	1650	430	360	380	22	230	250	403	150	136	1150	356	353	57	81	16	22	279	77.7	
1882	-	853	1800	406	406	-	-	-	-	433	-	126	1350	457	383	-	-	-	-	-	190.0	
1882	749	853	1800	390	390	240	22	360	200	433	28	126	1350	457	383	4	100	59	241	8	87.0	