

SCM-ST Series

STAINLESS STEEL CENTRIFUGAL PUMP



OPERATING CONDITIONS

- Liquid temperature up to 60°C
- Ambient temperature up to 40°C
- Continuous duty
- pH: 6.5 to 8.5

PUMP

- Pump Body: stainless steel
- Impeller: stainless steel
- Mechanical Seal: Carbon / Ceramic / Stainless Steel
- Front bracket: Aluminum

MOTOR

- Single Phase: IE1, IE2/IE3
- Heavy Duty Continuous Work
- Motor Housing: Aluminum
- Shaft: AISI304/AISI420/AISI1045
- Insulation: Class B / Class F
- Protection: IPX4
- Cooling: External Ventilation

ADVANTAGES & FEATURES

- Stainless steel pump body and impeller.
- High efficiency
- Compact structure
- Good for water purify system, food industry and chemical

IDENTIFICATION CODES

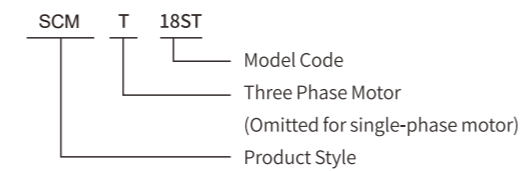

TECHNICAL DATA (220~240V/50Hz)

Model	Single-phase Motor				n=2850r/min			Dimensions (mm)			
	Input max kW	Output Power kW	HP	Current A	Q.max L/min	H.max m	Suct.max m	DNA		DNM	
SCM -18ST	0.55	0.37	0.50	2.5	100	18		1.25"	32	1"	25
SCM -20ST	0.80	0.55	0.75	3.8	110	20		1.25"	32	1"	25
SCM -26ST	1.10	0.75	1.00	5.2	120	26	9	1.25"	32	1"	25
SCM -34ST	1.50	1.10	1.50	7.0	140	34		1.25"	32	1"	25
SCM -37ST	2.00	1.50	2.00	9.6	160	39		1.25"	32	1"	25

Other voltages and frequencies available on request.

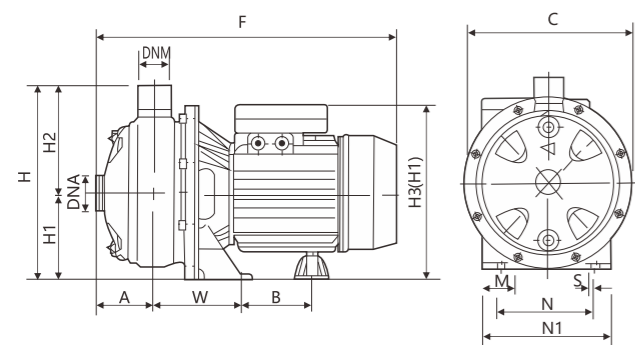

OVERALL & INSTALLATION DIMENSIONS

Model	Dimensions (mm)													
	a	c	f	h	h1	h2	h3	h4	m	n	n1	s	w	b
SCM -18ST	52	213	315	232	108	124	241	213	39	120	158	9	92	82
SCM -20ST	52	213	315	232	108	124	241	213	39	120	158	9	92	82
SCM -26ST	52	213	315	232	108	124	241	213	39	120	158	9	92	82
SCM -34ST SCM -37ST	52	240	365	257	120	137	241	213	39	140	180	9	92	82

MATERIALS TABLE

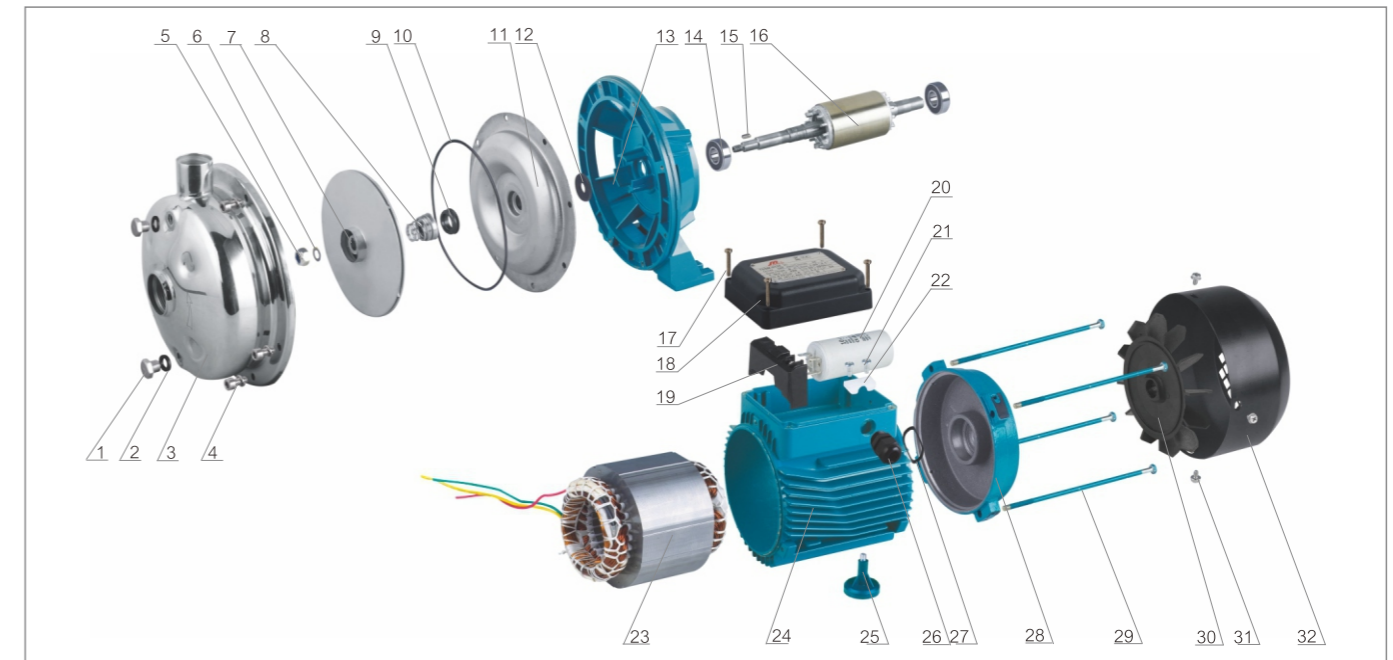

HYDRAULIC PERFORMANCE CURVES

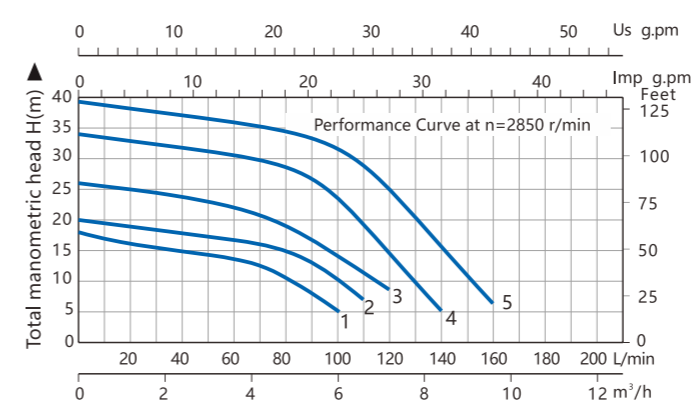

NO.	DESCRIPTION	NO.	DESCRIPTION
1	Air Screw	18	Terminal Box
2	O-Ring For Air Screw	19	Terminal Block
3	Pump Body	20	Capacitor
4	Hex Bolt	21	Screw For Cable Presser
5	Impeller Stop Nut	22	Cable Presser
6	Plain Washer	23	Stator With Winding
7	Impeller	24	Motor Housing
8	M-Seal Rotating Part	25	Motor Foot
9	M-Seal Static Ring	26	Cable Gland
10	Pump Body O-Ring	27	Adjusting Ring
11	M-Seal Holding Disc	28	Rear Cover
12	Splash Guard	29	Motor Tie-Rod
13	Motor Bracket	30	Fan
14	Bearing	31	Fan Cover Screw
15	Key	32	Fan cover
16	Shaft And Rotor		
17	Screw For T-Box		

PACKAGE INFORMATION

Model	Package dimensions & G.W. (mm)				MOQ
	L	W	H	kg	Kraft carton pcs
SCM-18ST	390	220	270	12.0	300
SCM-20ST	390	220	270	12.5	200
SCM-26ST	390	220	270	13.5	200
SCM-34ST SCM-37ST	400	250	325	24.0	100

